









ventus vvs/s-type

WING
Fan Coil Unit

2024





	01 VTS Group	
1.1.	VTS Group	06
1.2.	3 pillars of success	08
	02 Support for designers	
2.1.	ClimaCad Online 4.0	12
2.2.	VTS BIM	14
	03 VENTUS VVS Air Handling Units	
3.1.	General specification	18
3.2.	Technical specification	26
3.2.3.	VVS 021-120 - Regenerator (rotary heat wheel)	26
3.2.4.	VVS 150-650- Regenerator (rotary heat wheel)	28
3.2.5.	VVS 21-120 - Supply & Exhaust	30
3.2.6.	VVS 150-650 - Supply & Exhaust	32
3.2.6.	Additional configuration functions - VVS 021-650 - regenerator (rotary heat wheel), supply & exhaust	34
3.3.	Components	36
3.4.	Controls	44
3.4.1.	Description	44
3.4.2.	Control elements	48
	04 VENTUS S-type Air Handling Units	
4.1.	Technical specification	56
	05 Fan Coil Unit	
5.1.	Technical specification	62
	06 WING units	
6.1.	WING	68
	07 Psychrometric chart (Mollier)	
7.1.	Psychrometric chart (Mollier)	73

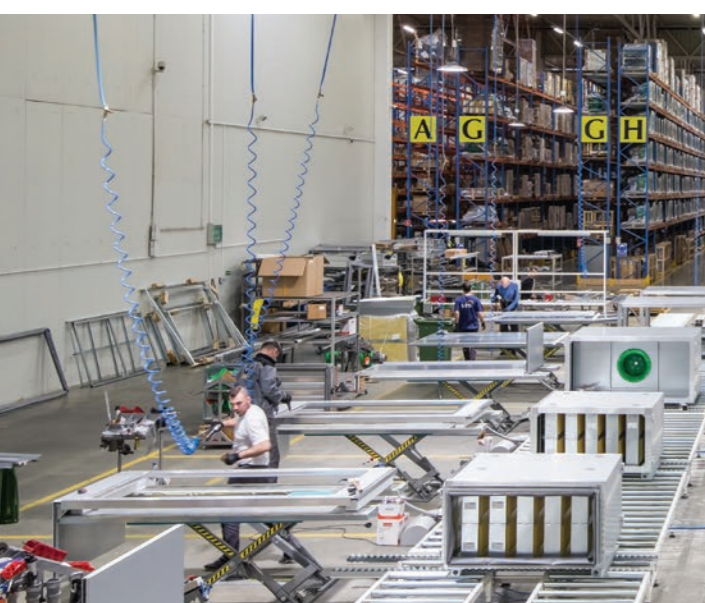

 **01**
VTS Group



VTS GROUP – is a manufacturer of technically advanced HVAC equipment, combining innovative technologies in the field of research&development, production and logistics.

OUR MISSION

AHU#1

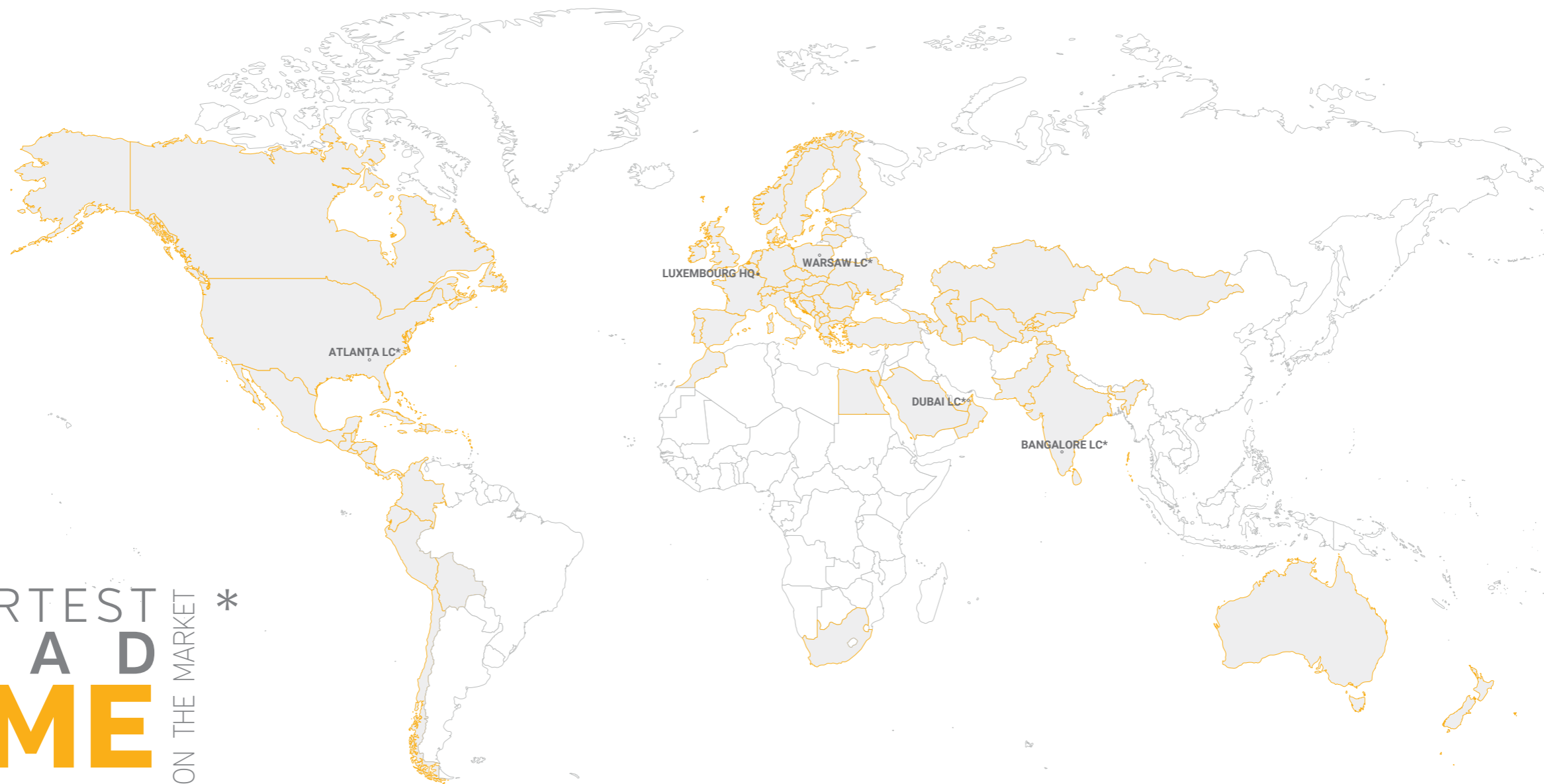

SHORTEST
LEAD
TIME ON THE MARKET *

* Logistics center





3 PILLARS OF SUCCESS

Constantly highest quality of products. Best prices on the market. Shortest lead time. These 3 pillars of marketing policy allows VTS to be always one step head, wherever in the world.

Following the best practices of the branch, VTS has created a network of 4 efficiently running production and logistic centers (**Atlanta, Dubai, Warsaw, Bangalore**), enable to ensure the shortest lead time on the market, wherever in the world.

Large-scale production of repetitive units allow VTS to offer them at **the most competitive price, simultaneously keeping their highest possible quality**

Multistage quality control system allows VTS to offer **2 years warranty, extendable even up to 5.**

SHORTEST
LEAD
TIME ON THE MARKET



COMPETITIVE
PRICE

150 000
UNITS
SOLD ANNUALLY

BEST
QUALITY

UP TO 5 YEARS WARRANTY FOR EACH UNIT





02

Support
for designers

CLIMACAD ONLINE 4.0 [CCOL 4]



Infinite number of configurations

Friendly user interface

Simple and easy selection

Integration with CRM, ERP & WMA systems

Certified by



CCOL4 OPTIMIZED FOR

» any web-browser



» any operating system



» any device



DATA EXPORT TO



CCOL 4.0 utilises latest technologies and software platforms. The tool has been developed in SaaS model (Software as a Service). It's best advantage is, that service is accessible wherever in the world. Any device equipped with web-browser and internet access is all you need to experience the power of our CCOL 4.0.

DESIGN VERSATILITY

- » Infinite units configurations.
- » Detecting of configurations errors.

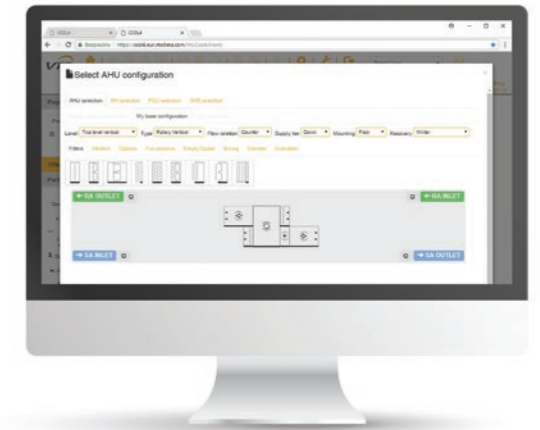

DYNAMIC AHU LENGTH DEFINITION

- » CCOL4 applies dynamic optimizing of AHU length based on automatic air treatment functions. placements with regard to minimum gaps between them in order to secure their proper performance.

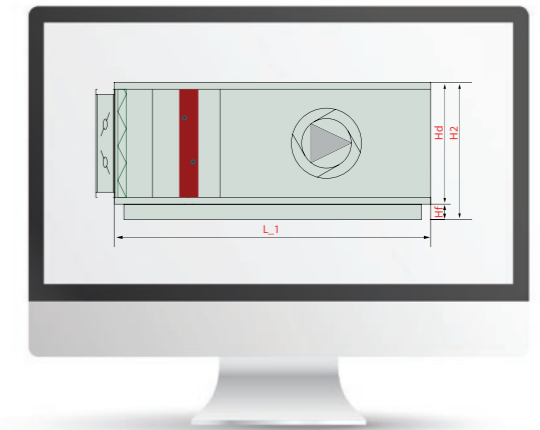

MANAGING OF YOUR DATA BASE

- » Self-creating and development by designer of own projects and AHU selections data base.
- » Sharing of self-made AHU selections with VTS enginners for pricing.

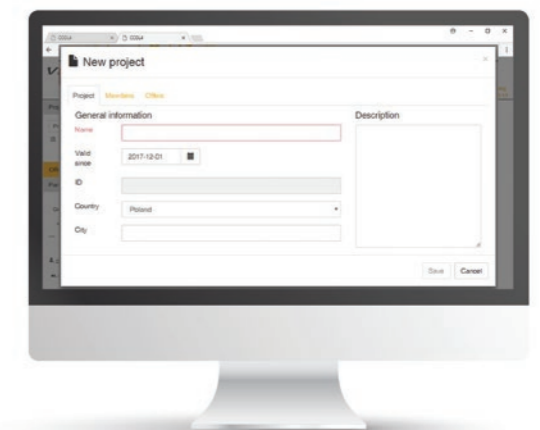

VTS BIM - new approach to digital models of Air Handling Units

VTS has enabled dynamic generating of VENTUS VVS, VENTUS Compact and American VENTUS AVS units digital models as on-line service. This became possible thanks to implementation of new AHU selection tool – the ClimaCAD OnLine 4.0 [CCOL 4.0], equipped with .rfa [Revit®] files generator.

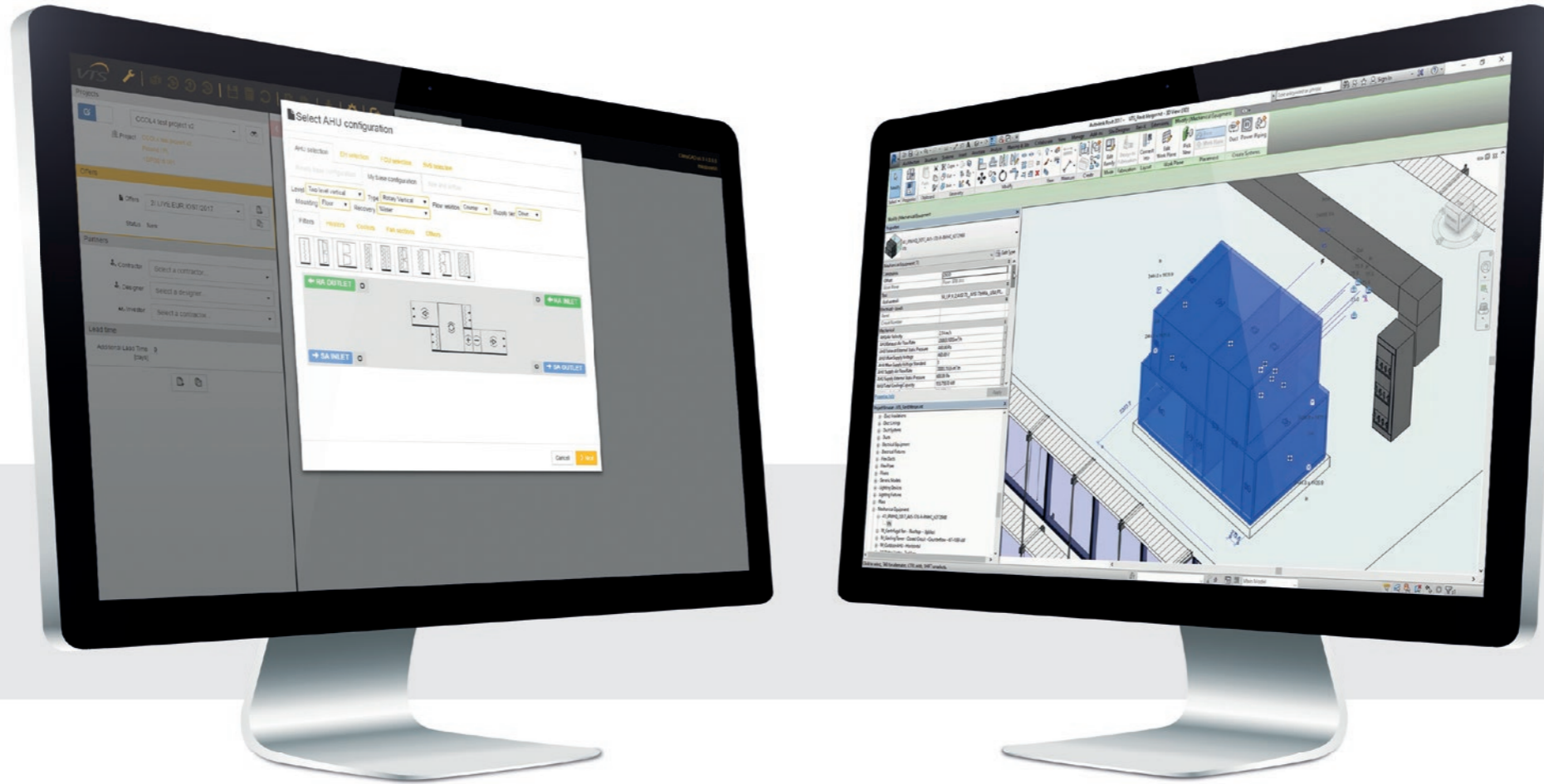

The Autodesk REVIT® families shared by VTS significantly facilitate entire building modelling process done by designing bureaus. At the moment, the generator is a unique tool in entire BIM environment. It enables to generate brand new VENTUS units model on the spot, in any configuration or any parameters.

3 steps to generate the model:

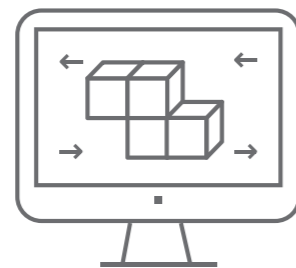

1 Login to CCOL 4.0

You can login using our web-site:

www.ccol4.com

2 AHU configuration and parameters specifying

Intuitive unit configurator enables to select a unit, perfectly fitting to your design assumptions.

3 Selection export to .fra file

In order to generate .fra model, all you need to do is to enter personal information (including e-mail address) of a person to whom the model is to be sent. The system will automatically sent the link to the site from where model can be downloaded. Entire process take no longer than 15 minutes.

As a result the client is given:

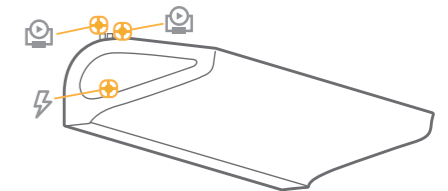
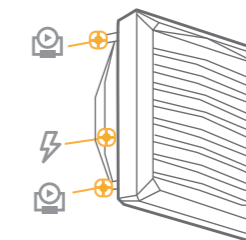
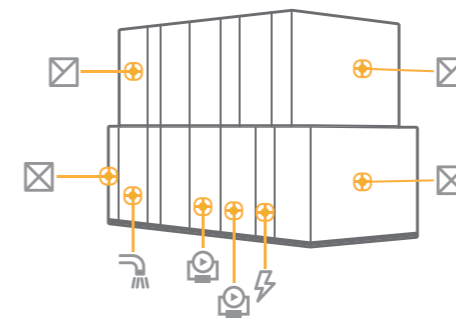

Digital model of the air handling unit with fully parametrized connectors:

- » Air,
- » Hydraulic,
- » Sanitary,
- » Electric,

and also a set of complete technical and dimensioning information, including clearly marked **maintenance** and **service zone** of the unit.

VTS enables also a library of static families for WING air curtains and VOLCANO air heaters.

The models includes:

- » parametrized electric and hydraulic connectors,
- » both vertical and horizontal mounting options,
- » presentation of units effective air range,
- » parametrized angle of heater's to the horizontal plane.



VTS **BIM** -air handling units perfectly fitted for designer's needs.

VTS supports generating of air handling units models in LOD 400 (Level Of Development) standard. In 2019, ClimaCAD OnLine 4.0 will support customization of the model's Level of Development, at the moment of their generating.

This will make the designing process even more flexible, especially when making first approaches to general concept of the building HVAC installations.

LOD 400 as standard

The VENTUS BIM families include maintenance and service zones of the units as standard.

These zones reserve minimum space to secure proper maintenance and repair conditions of the unit, and allow to avoid any collisions with remaining building elements or installations.

Service clearance **repair & maintenance** as standard.

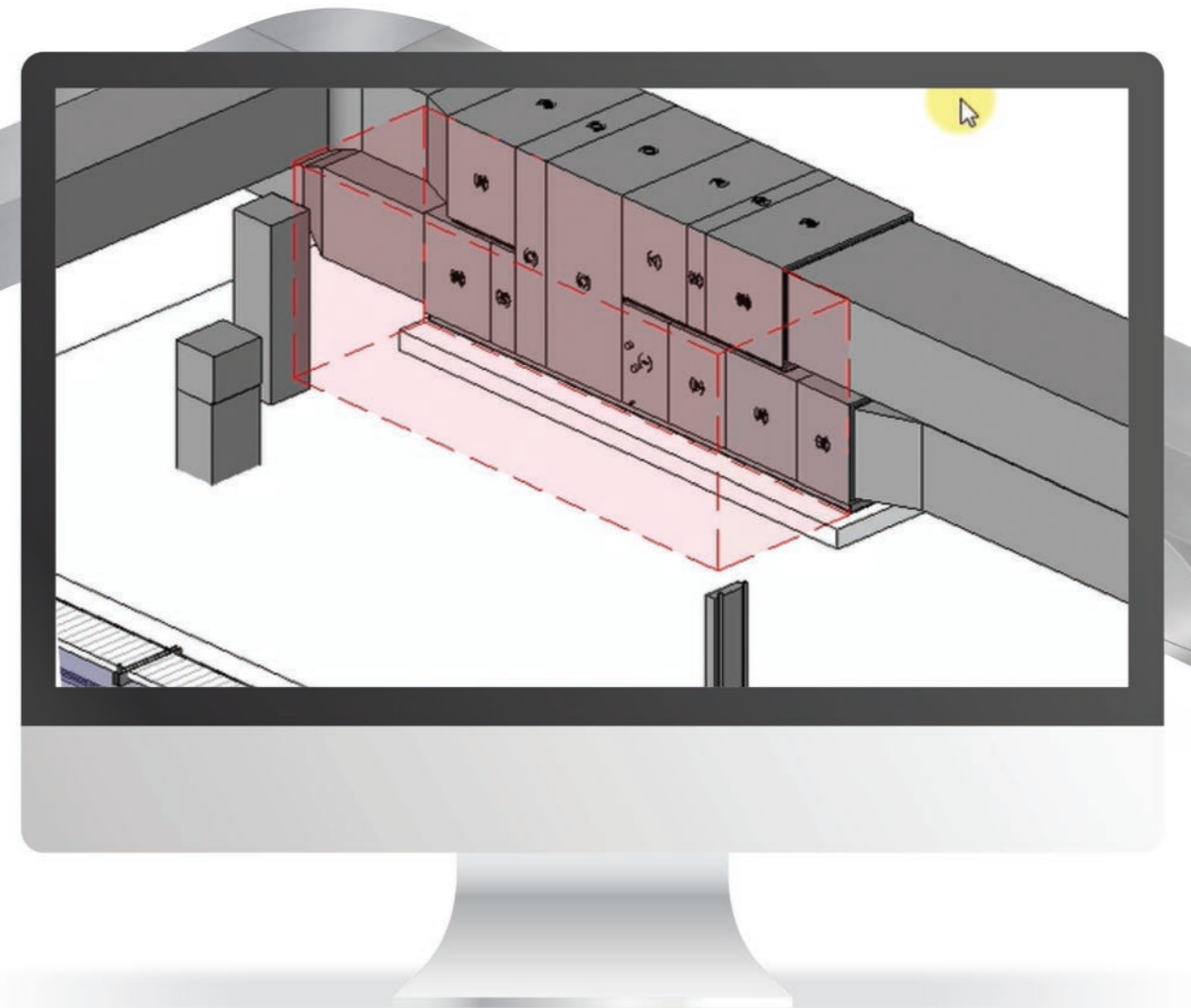
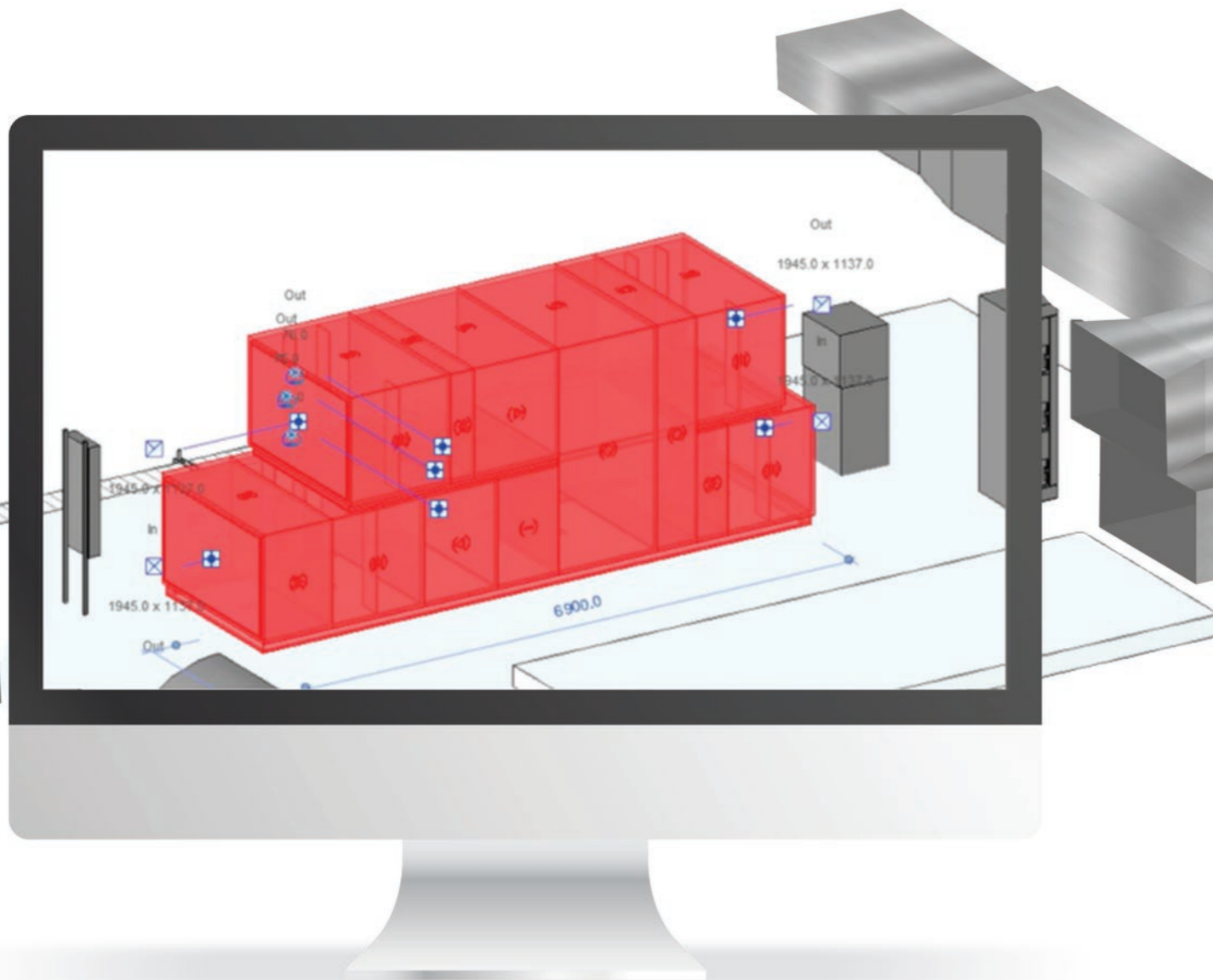



03

Units
- VENTUS VVS

ventus
VVS



Airflow

from **750** m³/h
to **100 000** m³/h



Up to **87%**
of energy recovery
efficiency



15
sizes



DURABLE
AND TIGHT
STRUCTURE



RELIABLE
COMPONENTS



SMART
CONTROLS



USER
SAFETY



STRUCTURE



FOOTS
VS 21-150



C PROFILE
VS 180-650

GALVANIZED STEEL SUPPORT
AS **STANDARD** FOR ALL TYPES
OF UNITS

FRAME

- » easier transport
- » greater profile resistance to deflection



FAN SECTION CAGE

- » increased longitudinal stiffness of the structure
- » easier sections assembly

ALUMINIUM COLUMNS
AS **STANDARD**
FOR ALL TYPES
OF UNITS

STRUCTURAL COLUMNS

- » thermal breaks on the mullion as standard
- » high resistance to weather conditions and UV rays



TIGHTNESS

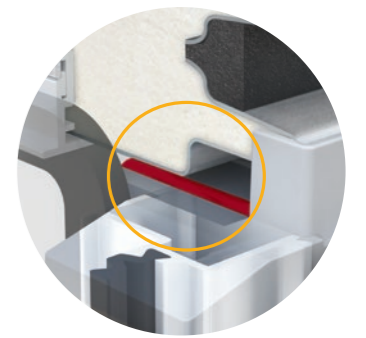
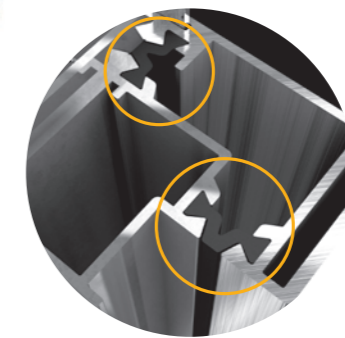
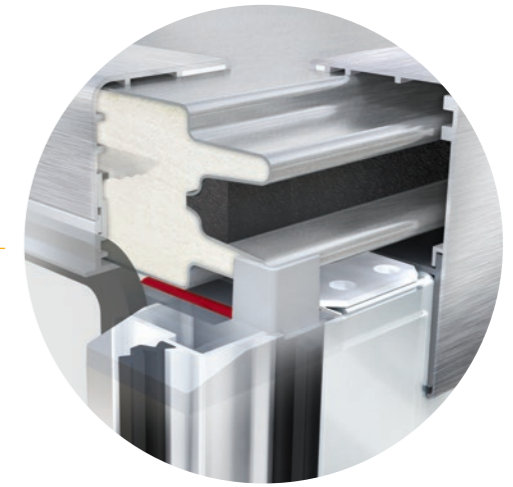

THERMAL BREAK

LABIRYNTH TIGHTENING

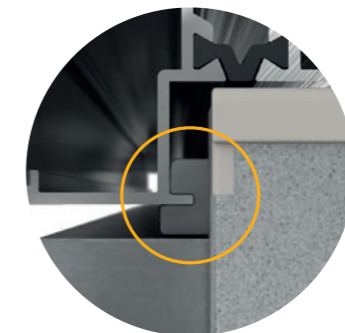

ADDITIONAL POST SEALING

ADDITIONAL SEALING BLADE



CANOPY

- » The canopy is made of 0,5 mm steel sheet, double side coated with 185 um of zinc (DX51D AZ185).
- » Canopy is assembled of modules equipped with self-latching grooves securing perfect tightness of the joints. Modular structure of the canopy ensures its easy and safe assembly.

ERGONOMIC INSPECTION PANEL LOCK

- » Highly aesthetic and ergonomic handles securing perfect tightness of inspection panels.

ALUMINUM STRUCTURAL POSTS WITH ADDITIONAL SEALING BLADE AND THERMAL BREAK

- » Broken thermal bridge as standard – eliminates humidity condensation on units structural elements.
- » Blade along the inspection window ensures labyrinth tightening between panel and AHU body – currently the most effective solution on the market, mainly applied to laboratory equipment.
- » Symmetrical groove in the vertical post's mounting feet secures its 100% tightness with the AHU casing structure.

VVS 007-120 - ROTARY HEAT WHEEL

DIMENSIONS - VVS007-VVS120 - ROTARY HEAT WHEEL

Nominal parameters		Recommended airflow range																	
Unit size		VVS007	VVS021	VVS030	VVS040	VVS055	VVS075	VVS100	VVS120										
18 000 12 000 6 000 0	[m³/h]																		
		+	+	+	+	+	+	+	+	+	+	+	+	+	+	+	+	+	
		-	-	-	-	-	-	-	-	-	-	-	-	-	-	-	-	-	-
		0	0	0	0	0	0	0	0	0	0	0	0	0	0	0	0	0	0
Min airflow	600	806	1180	1958	2878	3805	4863	5815	5815	5815									
Max airflow	1350	2415	3900	5200	7150	9750	13000	15600	15600	15600									
H _{fd}	90	90	90	90	90	90	90	90	90	90									
H _{fu}	0	0	0	0	0	0	0	0	0	0									
H	503,5	558	690	690	825	945	1045	1082	1082	1082									
W	767	981	981	1188	1359	1500	1680	1911	1911	1911									
H _i	304	368	500	500	635	755	855	892	892	892									
W _i	667	881	881	1088	1259	1400	1580	1811	1811	1811									
H ₂	827	1026	1290	1290	1560	1800	2000	2074	2074	2074									
I	50	50	50	50	50	50	50	50	50	50									
Selected configurations Dimension		Length of selected configurations																	
	L2	1 830	1 830	1 830	2 196	2 196	2 562	2 562	2 562	2 562									
	L1	1 830	1 830	1 830	2 196	2 196	2 562	2 562	2 562	2 562									
	L2	2 562	2 562	2 562	2 928	2 928	3 294	3 294	3 294	3 294									
	L1	2 562	2 562	2 562	2 928	2 928	3 294	3 294	3 294	3 294									
	L2	1 830	1 830	1 830	2 196	2 196	2 562	2 562	2 562	2 562									
	L1	2 196	2 196	2 196	2 562	2 562	2 928	2 928	2 928	2 928									
	L2	2 562	2 562	2 562	2 928	2 928	3 294	3 294	3 294	3 294									
	L1	2 928	2 928	2 928	3 294	3 294	3 660	3 660	3 660	3 660									
	L2	1 830	1 830	1 830	2 196	2 196	2 562	2 562	2 562	2 562									
	L1	2 196	2 196	2 196	2 562	2 562	2 928	2 928	2 928	2 928									
	L2	2 562	2 562	2 562	2 928	2 928	3 294	3 294	3 294	3 294									
	L1	2 928	2 928	2 928	3 294	3 294	3 660	3 660	3 660	3 660									
	L2	3378	3378	3378	3744	3744	4110	4110	4110	4110									
	L1	4138	4138	4138	4504	4504	4870	4870	4870	4870									
	L2	1126																	
	L1	1222																	
	L2	1857																	
	L1	1953																	

Entire range of configuration in ClimaCAD OnLine 4 selection tool - www.ccol4.com

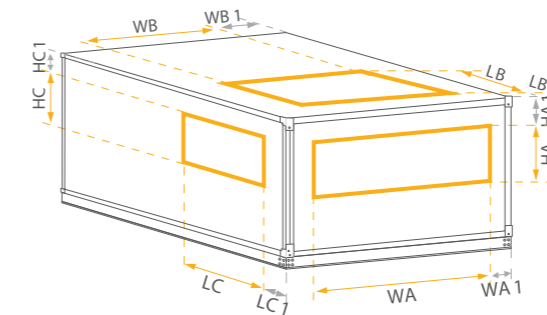
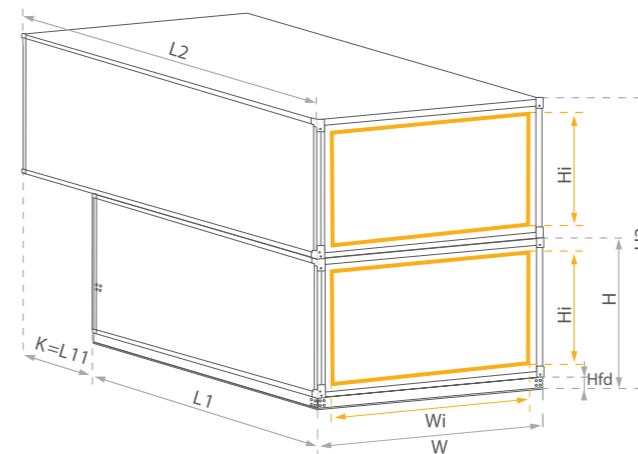

FAN OUTLET OPENINGS

Plug Fan END (FS)					
Size	WA	HA	WA1	HA1	
VVS021	500	210	230	119	
VVS030	700	210	130	185	
VVS040	600	310	284	135	
VVS055	850	310	244	202	
VVS075	900	400	290	217	
VVS100	1200	400	230	267	
VVS120	1400	400	245	286	

Opening BIG - inlet-outlet END (FF)					
Size	WA	HA	WA1	HA1	
VVS007	637	245	65	84	
VVS021	500	210	230	119	
VVS030	700	210	130	185	
VVS040	600	310	284	135	
VVS055	850	310	244	202	
VVS075	900	400	290	217	
VVS100	1200	400	230	267	
VVS120	1400	400	245	286	

Opening BIG - inlet-outlet END (US)					
Size	WB	LB	WB1	LB1	
VVS021	500	210	230	120	
VVS030	700	210	130	120	
VVS040	600	310	284	120	
VVS055	850	310	244	120	
VVS075	900	400	290	120	
VVS100	1200	400	230	120	
VVS120	1400	400	245	120	

Opening BIG - inlet-outlet END (BS)					
Size	LC	HC	LC1	HC1	
VVS021	112	150	120	149	
VVS030	112	200	120	190	
VVS040	112	250	120	165	
VVS055	112	350	120	182	
VVS075	112	500	120	167	
VVS100	210	350	120	292	
VVS120	210	400	120	286	

Plug Fan END (US)					
Size	WB	LB	WB1	LB1	
VVS021	500	210	230	119	
VVS030	700	210	130	185	
VVS040	600	310	284	135	
VVS055	850	310	244	202	
VVS075	900	400	290	217	
VVS100	1200	400	230	267	
VVS120	1400	400	245	286	

DIDW END (FS)					
Size	WA	HA	WA1	HA1	
VVS021	206	206	377	84	
VVS030	256	256	352	142	
VVS040	288	288	441	92	
VVS055	408	408	340	84	
VVS075	452	452	420	94	
VVS100	510	510	480	112	
VVS120	572	572	480	88	

DIDW END (US)					
Size	WB	LB	WB1	LB1	
VVS021	206	206	377	307	
VVS030	256	256	352	322	
VVS040	288	288	441	336	
VVS055	408	408	340	390	
VVS075	452	452	420	390	
VVS100	510	510	480	420	
VVS120	572	572	480	480	

VVS 150-650- ROTARY HEAT WHEEL

Nominal parameters		Recommended airflow range																							
Unit size		VVS150			VVS180			VVS230			VVS300			VVS400			VVS500			VVS650					
90 000		[Bar chart showing airflow ranges for each unit size]																							
60 000		[Bar chart showing airflow ranges for each unit size]																							
30 000		[Bar chart showing airflow ranges for each unit size]																							
0		[Bar chart showing airflow ranges for each unit size]																							
Min airflow		7 167			8 640			10 398			13 491			18 704			21 817			28 725					
Max airflow		19 500			23 400			29 900			39 000			52 000			71 500			84 500					
H _{fd}		90			90			90			120			120			120			120					
H _{fu}		0			0			0			60			60			60			60					
H		1183			1387			1387			1686			1919			1919			2396					
W		2105			2105			2513			2605			3105			3605			3717					
H _i		993			1197			1197			1496			1729			1729			2206					
W _i		2005			2005			2413			2505			3005			3505			3617					
H ₂		2276			2684			2684			3282			3748			3748			4702					
I		50			50			50			50			50			50			50					

Selected configurations: Dimension		Length of selected configurations																							
FRV/FRV_cd	L2	2 562			2 562			2 562			2 928			2 928			2 928			2 928					
	L1	2 562			2 562			2 562			2 928			2 928			2 928			2 928					
	K	1 098			1 098			1 098			1 464			1 464			1 464			1 464					
	Lt	2 562			2 562			2 562			2 928			2 928			2 928			2 928					
FRMV/FVMR_cd	L2	3 660			3 660			3 660			4 026			4 026			4 026			4 026					
	L1	3 660			3 660			3 660			4 026			4 026			4 026			4 026					
	K	0			0			0			0			0			0			0					
	Lt	3 660			3 660			3 660			4 026			4 026			4 026			4 026					
FRHV/FRV_cd	L2	2 562			2 562			2 562			2 928			2 928			2 928			2 928					
	L1	2 928			2 928			2 928			3 294			3 294			3 294			3 294					
	K	1 098			1 098			1 098			1 464			1 464			1 464			1 464					
	Lt	2 928			2 928			2 928			3 294			3 294			3 294			3 294					
FRMHV/FVMR_cd	L2	3 660			3 660			3 660			4 026			4 026			4 026			4 026					
	L1	4 026			4 026			4 026			4 392			4 392			4 392			4 392					
	K	0			0			0			0			0			0			0					
	Lt	4 026			4 026			4 026			4 392			4 392			4 392			4 392					
FRMVH/FVMR_cd	L2	2 562			2 562			2 562			2 928			2 928			2 928			2 928					
	L1	2 928			2 928			2 928			3 294			3 294			3 294			3 294					
	K	1 098			1 098			1 098			1 464			1 464			1 464			1 464					
	Lt	2 928			2 928			2 928			3 294			3 294			3 294			3 294					
FRMVCV/FVMR_cd	L2	3 660			3 660			3 660			4 026			4 026			4 026			4 026					
	L1	4 026			4 026			4 026			4 392			4 392			4 392			4 392					
	K	0			0			0			0			0			0			0					
	Lt	4 026			4 026			4 026			4 392			4 392			4 392			4 392					
FPDV/FVPD_cd	L2	4110			4138			4138			4504			4504			4504			4504					
	L1	4870			4898			4898			5264			5264			5264			5264					
	K	366			366			366			366			366			366			366					
	Lt	5236			5264			5264			5630			5630			5630			5630					

Entire range of configuration in ClimaCAD OnLine 4 selection tool - www.ccol4.com

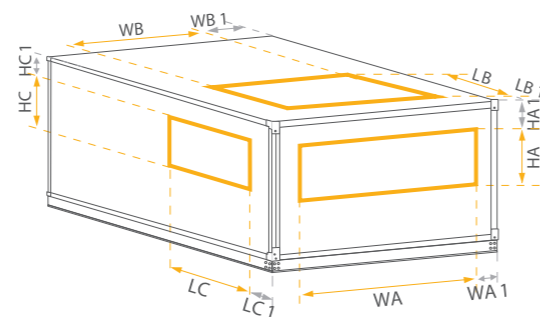
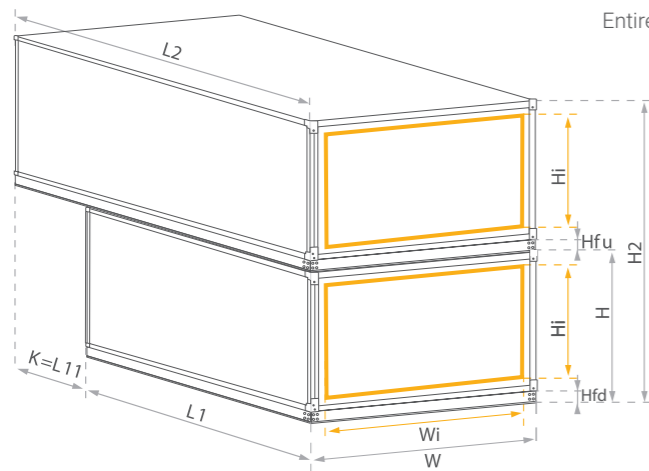

DIMENSIONS - VVS150-VVS650 - ROTARY HEAT WHEEL

Opening BIG - inlet-outlet END (FF)				
Size	WA	HA	WA1	HA1
VVS150	1400	500	342	286
VVS180	1700	500	192	388
VVS230	1800	600	346	338
VVS300	2060	700	262	438
VVS400	2760	700	162	554
VVS500	3060	800	262	504
VVS650	3360	900	168	693

Opening BIG - inlet-outlet END (US)				
Size	WB	LB	WB1	LB1
VVS150	1400	500	342	120
VVS180	1700	500	192	120
VVS230	1800	600	346	120
VVS300	2060	700	262	120
VVS400	2760	700	162	120
VVS500	3060	800	262	120
VVS650	3360	900	168	120

Opening BIG - inlet-outlet END (BS)				
Size	LC	HC	LC1	HC1
VVS150	210	500	120	286
VVS180	210	600	120	338
VVS230	310	550	120	363
VVS300	310	700	120	438
VVS400	310	900	120	454
VVS500	400	900	120	454
VVS650	400	1150	120	568

FAN OUTLET OPENINGS

Plug Fan END (FS)				
Size	WA	HA	WA1	HA1
VVS150	500	210	230	119
VVS180	700	210	130	185
VVS230	600	310	284	135
VVS300	850	310	244	202
VVS400	900	400	290	217
VVS500	1200	400	230	267
VVS650	1400	400	245	286

DIDW END (FS)				
Size	WA	HA	WA1	HA1
VVS150	642	642	610	98
VVS180	718	718	480	162
VVS230	804	804	770	112
VVS300	902	902	740	172
VVS400	1010	1010	1040	470
VVS500	1134	1134	1230	102
VVS650	1270	1270	1215	180

Plug Fan END (US)				
Size	WB	LB	WB1	LB1
VVS150	1400	500	342	286
VVS180	1700	500	192	388
VVS230	1800	600	346	338
VVS300	2060	700	262	438
VVS400	2760	700	162	554
VVS500	3060	800	262	504
VVS650	3360	900	168	693

DIDW END (US)				
Size	WB	LB	WB1	LB1
VVS150	642	642	610	510
VVS180	718	718	480	520
VVS230	804	804	770	600
VVS300	902	902	740	600
VVS400	1010	1010	1040	640
VVS500	1134	1134	1230	700
VVS650	1270	1270	1215	720

VVS021-VVS150 - SUPPLY & EXHAUST

DIMENSIONS - VVS021-VVS120 - SUPPLY & EXHAUST

Nominal parameters		Recommended airflow range																											
Unit size		VVS021				VVS030				VVS040				VVS055				VVS075				VVS100				VVS120			
20 000	[m³/h]	[Bar chart showing airflow range for each unit size]																											
15 000		[Bar chart showing airflow range for each unit size]																											
10 000		[Bar chart showing airflow range for each unit size]																											
5 000		[Bar chart showing airflow range for each unit size]																											
0		[Bar chart showing airflow range for each unit size]																											
Min airflow		806	806	806	806	1180	1180	1167	1167	1958	1958	1958	1958	2878	2878	2878	2878	3805	3805	3805	3805	4863	4863	4863	4863	5815	5815	5815	5815
Max airflow		2163	2730	3570	3780	3090	3900	5100	5400	4120	5200	6800	7200	5665	7150	9350	9900	7725	9750	12750	13500	10300	13000	17000	18000	12360	15600	20400	21600
H _{fd}		90				90				90				90				90				90							
H	[mm]	558				690				690				825				945				1045				1082			
W		981				981				1188				1359				1500				1680				1911			
H _i		368				500				500				635				755				855				892			
W _i		881				881				1088				1259				1400				1580				1811			
I		50				50				50				50				50				50				50			

Selected configurations		Dimension		Length of selected configurations						
	F-CV	Lt	[mm]	1181*	1181*	1181*	1547	1547	1913	1913
	MFCV	Lt	[mm]	1490*	1490*	1490*	1856	2221	2587	2587
	FCV	Lt	[mm]	1572*	1572*	1572*	1938	1938	2303	2303
	MFFCV	Lt	[mm]	2221*	2221*	2221*	2587	2587	2953	2953
	FV	Lt	[mm]	1098	1098	1098	1464	1464	1830	1830
	V	Lt	[mm]	732	732	732	1098	1098	1464	1464

Entire range of configuration in ClimaCAD OnLine 4 selection tool - www.ccol4.com

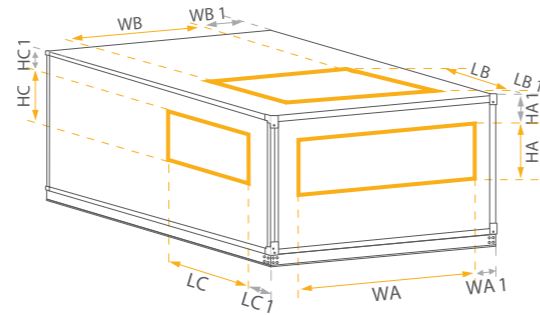
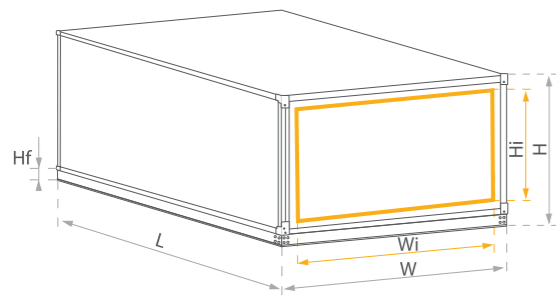

General:
 * If 8RD with eliminator, length will increase by 366mm
 ** If RA is required on top, length will increase by 366mm

Opening BIG - inlet-outlet END (FF)				
Size	WA	HA	WA1	HA1
VVS021	500	210	230	119
VVS030	700	210	130	185
VVS040	600	310	284	135
VVS055	850	310	244	202
VVS075	900	400	290	217
SSV100	1200	400	230	267
VVS120	1400	400	245	286

Opening BIG - inlet-outlet END (US)				
Size	WB	LB	WB1	LB1
VVS021	500	210	230	120
VVS030	700	210	130	120
VVS040	600	310	284	120
VVS055	850	310	244	120
VVS075	900	400	290	120
SSV100	1200	400	230	120
VVS120	1400	400	245	120

Opening BIG - inlet-outlet END (BS)				
Size	LC	HC	LC1	HC1
VVS021	112	150	120	149
VVS030	112	200	120	190
VVS040	112	250	120	165
VVS055	112	350	120	182
VVS075	112	500	120	167
SSV100	210	350	120	292
VVS120	210	400	120	286

FAN OUTLET OPENINGS

Plug Fan END (FS)				
Size	WA	HA	WA1	HA1
VVS021	500	210	230	119
VVS030	700	210	130	185
VVS040	600	310	284	135
VVS055	850	310	244	202
VVS075	900	400	290	217
SSV100	1200	400	230	267
VVS120	1400	400	245	286

DIDW END (FS)				
Size	WA	HA	WA1	HA1
VVS021	206	206	377	84
VVS030	256	256	352	142
VVS040	288	288	441	92
VVS055	408	408	340	84
VVS075	452	452	420	94
SSV100	510	510	480	112
VVS120	572	572	480	88

Plug Fan END (US)				
Size	WB	LB	WB1	LB1
VVS021	500	210	230	119
VVS030	700	210	130	185
VVS040	600	310	284	135
VVS055	850	310	244	202
VVS075	900	400	290	217
SSV100	1200	400	230	267
VVS120	1400	400	245	286

DIDW END (US)				
Size	WB	LB	WB1	LB1
VVS021	206	206	377	307
VVS030	256	256	352	322
VVS040	288	288	441	336
VVS055	408	408	340	390
VVS075	452	452	420	390
SSV100	510	510	480	420
VVS120	572	572	480	480

VVS 150-650 - SUPPLY & EXHAUST

DIMENSIONS - VVS150-VVS650 - SUPPLY & EXHAUST

Nominal parameters		Recommended airflow range						
Unit size		VVS150	VVS180	VVS230	VVS300	VVS400	VVS500	VVS650
120 000	[m³/h]							
90 000								
60 000								
30 000								
0								
Min airflow		7 167	7 167	7 167	7 167	8 640	8 640	8 640
Max airflow		15 450	19 500	25 500	27 000	18 540	23 400	30 600
H _{fd}	[mm]	90	90	90	120	120	120	120
H		1183	1387	1387	1686	1919	1919	2396
W		2105	2105	2513	2605	3105	3605	3717
H _i		993	1197	1197	1496	1729	1729	2206
W _i		2005	2005	2413	2505	3005	3505	3617
I		50	50	50	50	50	50	50

Selected configurations Dimension		Length of selected configurations						
	Lt	1913	1913	1913	2278	2278	2278	2278
	Lt	2587	2587	2587	2953	2953	2953**	2953**
	Lt	2303	2303	2303	2669	2669	2669	2669
	Lt	2953	2953	2953	3318	3318	3318**	3318**
	Lt	1830	1830	1830	2196	2196	2196	2196
	Lt	1464	1464	1464	1830	1830	1830	1830

Entire range of configuration in ClimaCAD OnLine 4 selection tool - www.ccol4.com

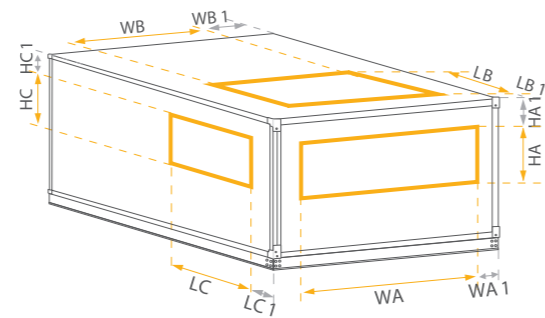
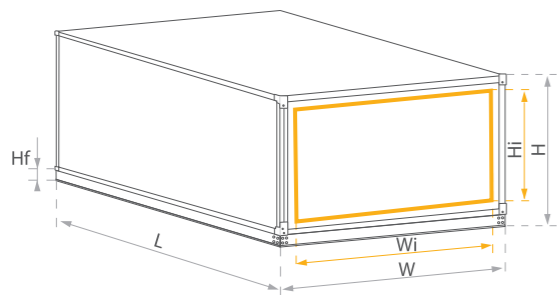

General:
 * If 8RD with eliminator, length will increase by 366mm
 ** If RA is required on top, length will increase by 366mm

Opening BIG - inlet-outlet END (FF)				
Size	WA	HA	WA1	HA1
VVS150	1400	500	342	286
VVS180	1700	500	192	388
VVS230	1800	600	346	338
VVS300	2060	700	262	438
VVS400	2760	700	162	554
VVS500	3060	800	262	504
VVS650	3360	900	168	693

Opening BIG - inlet-outlet END (US)				
Size	WB	LB	WB1	LB1
VVS150	1400	500	342	120
VVS180	1700	500	192	120
VVS230	1800	600	346	120
VVS300	2060	700	262	120
VVS400	2760	700	162	120
VVS500	3060	800	262	120
VVS650	3360	900	168	120

Opening BIG - inlet-outlet END (BS)				
Size	LC	HC	LC1	HC1
VVS150	210	500	120	286
VVS180	210	600	120	338
VVS230	310	550	120	363
VVS300	310	700	120	438
VVS400	310	900	120	454
VVS500	400	900	120	454
VVS650	400	1150	120	568

FAN OUTLET OPENINGS

Plug Fan END (FS)				
Size	WA	HA	WA1	HA1
VVS150	500	210	230	119
VVS180	700	210	130	185
VVS230	600	310	284	135
VVS300	850	310	244	202
VVS400	900	400	290	217
VVS500	1200	400	230	267
VVS650	1400	400	245	286







DIDW END (FS)				
Size	WA	HA	WA1	HA1
VVS150	642	642	610	98
VVS180	718	718	480	162
VVS230	804	804	770	112
VVS300	902	902	740	172
VVS400	1010	1010	1040	470
VVS500	1134	1134	1230	102
VVS650	1270	1270	1215	180







Plug Fan END (US)				
Size	WB	LB	WB1	LB1
VVS150	1400	500	342	286
VVS180	1700	500	192	388
VVS230	1800	600	346	338
VVS300	2060	700	262	438
VVS400	2760	700	162	554
VVS500	3060	800	262	504
VVS650	3360	900	168	693

DIDW END (US)				
Size	WB	LB	WB1	LB1
VVS150	642	642	610	510
VVS180	718	718	480	520
VVS230	804	804	770	600
VVS300	902	902	740	600
VVS400	1010	1010	1040	640
VVS500	1134	1134	1230	700
VVS650	1270	1270	1215	720



ADDITIONAL CONFIGURATION CUNCTIONS - VVS 021-650 - REGENERATOR (HEAT WHEEL), SUPPLY & EXHAUST

Dimension		Function version	Remaining configuration functions – typical lengths of function arrangement						
			VVS021	VVS030	VVS040	VVS055	VVS075	VVS100	VVS120
	L	F7/F9	762	762	762	762	762	762	762
		EU4/F5	366	366	366	366	366	366	366
	L	H	366	366	366	366	366	366	366
	L	C	366	366	366	366	366	366	366
	L	S	1098	1098	1098	1098	1098	1098	1098
	L	E(e1)	366	366	366	366	366	366	366
		E(e2)	762	762	762	762	762	762	762
		E(e3)	1098	1098	1098	1098	1098	1098	1098
	L	M	762	762	762	762	762	762	762
	L	W	1098	1098	1098	1098	1098	1098	1098

Dimension		Function version	Remaining configuration functions – typical lengths of function arrangement						
			VVS150	VVS180	VVS230	VVS300	VVS400	VVS500	VVS650
	L	F7/F9	762	762	762	762	762	762	762
		EU4/F5	366	366	366	366	366	366	366
	L	H	366	366	366	366	366	366	366
	L	C	366	366	366	366	366	366	366
	L	S	1098	1098	1098	1098	1098	1098	1098
	L	E(e1)	366	366	366	366	366	366	366
		E(e2)	762	762	762	762	762	762	762
		E(e3)	1098	1098	1098	1098	1098	1098	1098
	L	M	1098	1098	1098	1098	1098	1098	1098
	L	W	1098	1098	1098	1098	1098	1098	1098





COMPONENTS

FAN SET

> DIRECT DRIVE PLUG FAN SET



Design and application

- » Single inlet, radial, backward curved, free running fan.
- » Impeller made of SAN (styrene/acrylonitrile) construction material with 20% glass fiber.
- » Direct drive – fan impeller installed directly on motor shaft.
- » Fan section consisting of single or multiple fans (fan array) in order to ensure optimum working parameters.

Specification

- » Low and medium pressure ventilation systems with fan static pressure not exceeding 2000 Pascals.
- » Maximum fan set working temperature: 60°C.
- » Compliance with standards: EN 1886, EN 25136, ISO 5801, AMCA standard 210.

> BELT DRIVE DIDW FAN SET



- » The DIDW centrifugal fans (Double Inlet Double Width Fans) are suitable for supply or extract applications in commercial, process and industrial HVAC systems.
- » Sizes are in accordance with AMCA standard 99-0098-76 R20.
- » The operating limit is design to meet the requirement of class I, II and III limit as defined in AMCA standard 99-2408-69.

Wheel

- » The wheels are available in options:
 - Forward curved blades,
 - Backward curved bladed (air foil or straight shape)
- » The impeller with forward curved blades is manufactured in galvanized sheet steel.
- » The impeller with backward inclined blades is made of cold rolled sheet steel backward curved blades with polyester powder coating finish.

Housing

- » For all sizes the housing is manufactured in galvanized sheet steel with the housing fixed to the side plates in "pittsburg lock" form system.

Frame

- » The frame is manufactured with galvanized angular bars or steel finished with polyester powder coating.

Shaft

- » Shafts are manufactured from C45 carbon steel coated with an anti-corrosion varnish after assembly.

Bearings

- » Bearings used are either deep groove ball bearing type with an eccentric locking collar or an adapter sleeve, or spherical roller bearings type sealed at both sides for different duty.

> AC MOTORS



- » Fan and motor mounted on common housing, separated from AHU casing by set of rubber vibration absorbing mounts.
- » Motors of TEFC type (Totally Enclosed, Fan-Cooled).
- » Motors fitted for IEC standard.
- » Variable Frequency Drive (VFD) – standard equipment of the fan-set.

- » Available Energy classes: IE3
- » Rated voltage: 3x230V AC, 3x400V AC.
- » Number of poles: 2 or 4.
- » Motor winding insulation class: F (fitted for VFD operations).
- » Bearings lifetime: $L_{10} = 20000h$ / $L_{50} = 100000h$.
- » Protection degree: IP55.
- » Maximum working ambient temperature: 60°C.

CASING



Design and application

- » Casing structure made of 'sandwich' type panels formed in 'C' shape and reinforced by system of internal frames.
- » "Sandwich" double skin panels made of rigid polyurethane foam.
- » Indoor and outdoor application.
- » Inspection panels mounted on AHU side.
- » Casing supported on steel base rails.

Specification

- » Working temperature: (-40)°C ÷ (+90)°C.
- » Panel thickness: 50mm.
- » Thermal conductivity PPU $\lambda = 0,022$ W/mK.
- » Casing fire resistance: non-flammable, non fire spreading (NRO).
- » Moisture absorption: 0,04%.
- » PPU density: $\rho = 42$ kg/m³.

PANEL FILTERS



Design and application

- » Box Type
- » Pleated filtration fabric shielded by steel net, installed in 50 mm thick frame.
- » Filtration fabric made of polyester fibres.
- » Applied as initial air filtration stage.

Specification

- » Working temperature: max (+70)°C, 100% RH.

Filtration classes available

- » ISO Coarse 75% (ISO 16890) - G4 (EN779).

BAG FILTERS



Design and application

- » Flange Type & Bag Type
- » Filtration fabric made of polyester fibres.
- » Bags fixed to 25 mm thick frame.
- » Length: 300/600 mm.
- » Applied as initial, secondary or final air filtration stage.

Specification

- » Working temperature: max (+70)°C, 100% RH.

Filtration classes available

- » ISO ePM10 50% (ISO 16890) - M5 (EN779).
- » ISO ePM2,5 65% (ISO 16890) - F7 (EN779).
- » ISO ePM1 70% (ISO 16890) - F9 (EN779).

HEPA FILTERS

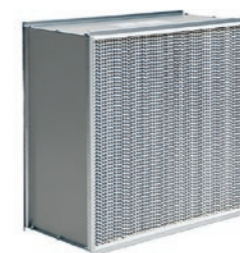

Design and application

- » Flange Type & Box Type
- » Filter Media: Glass Fiber / Spun Bonded Polyester
- » Length 300/600 mm.
- » Applied as final air filtration stage
- » Frame Material: Aluminum (SS 304 / GI (Galvanized Steel))

Specification

- » Working temperature: max (+70)°C, 100% RH.

Filtration classes available

- » H13 (EN 1822).
- » Filtration Rating: 0.3 Micron & More
- » Filtration Efficiency: 90- 99.9 %

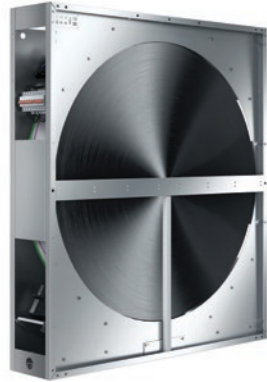

ROTARY HEAT WHEEL

**Design and application**
Non-hygroscopic

- » Rotor made of circular aluminum honeycomb matrix with shaft suspended on bearings, installed in steel housing.
- » Rotor filling – two layers of alternately wound aluminium foil – one flat, the other – corrugated – making small ducts for the air.
- » Rotor drive system with smooth revolutions control enabling to maintain highest recovery efficiency and to adjust degree of recovery performance.
- » Purge zone reducing the cross-contamination effect of contaminated exhaust air to supply to absolute minimum.
- » Set of gaskets installed both on the wheel outer edge and bar separating supply from exhaust air being an additional protection against cross-contamination.
- » Rotary heat wheel recovers sensible heat from return air to supply, which passes the unit in opposite direction. The process enables heat recovery in winter time, same as cool recovery in summer.
- » Bearings: Permanently sealed and lubricated ball bearings. Oversized bearings designed for over 200 000 hours of duty (20 000 L10 hours of duty).

Total - sorption

- » Rotor made of circular aluminum honeycomb matrix with shaft suspended on bearings, installed in steel housing.
- » Rotor's aluminium with with desiccant coating for latent recovery.

- » Rotor filling – two layers of alternately wound aluminium foil – one flat, the other – corrugated – making small ducts for the air.
- » Rotor drive system with smooth revolutions control enabling to maintain highest recovery efficiency and to adjust degree of recovery performance.
- » Purge zone reducing the cross-contamination effect of contaminated exhaust air to supply to absolute minimum.
- » Set of gaskets installed both on the wheel outer edge and bar separating supply from exhaust air being an additional protection against cross-contamination.
- » Desiccant type: 3A molecular sieve as desiccant for fast absorption of moisture and antimicrobial properties
- » Rotary heat wheel recovers both sensible and latent heat from return air to supply, which passes the unit in opposite direction. The process enables heat recovery in winter time, same as cool recovery in summer.
- » Bearings: Permanently sealed and lubricated ball bearings. Oversized bearings designed for over 200 000 hours of duty (20 000 L10 hours of duty).

Specification

- » Up to 86% of energy recovery, depending on airflow rate and its velocity in the heat wheel window.
- » Compliance with standards: EN 308, EN 13053.

MIXING SECTION

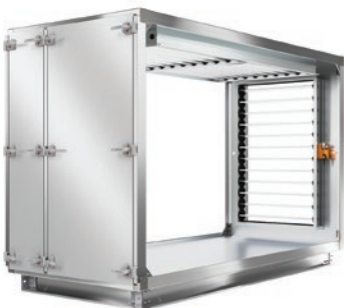
**Design and application**

- » Section equipped with two air inlets/outlets aided with dampers, enabling regulation of fresh and recirculation air share (recirculation).

Specification

- » Direct Energy recovery (sensible and latent heat) resulting from partial mixing of fresh air with return one.
- » Control of fresh air share in entire airflow supplied to handled spaces.
- » Working temperature range: -40 ÷ +70°C.



THE DOUBLE WHEEL CONCEPT

The double wheel system is one of the most effective systems for air dehumidifying with energy recovery. This concept perfectly combines energy recovery with dehumidification. This system uses both total-sorption thermal wheel and a non-hygroscopic thermal wheel with a cooling coil in between.



- » The Double Wheel Concept saves up to 60% of the total cooling capacity and requires lower investment and running costs compared to traditional systems. As rule of thumb, the additional cost of the sensible wheel can be saved in the lower investment compared to traditional system components, coils, chillers, cold and hot water piping installation, pumps, valves, controls and electric power supply costs. Accurate total investment costs analyze of the complete installation will show major savings in initial costs. Both cooling and heating energy savings will be additional profit of the investment

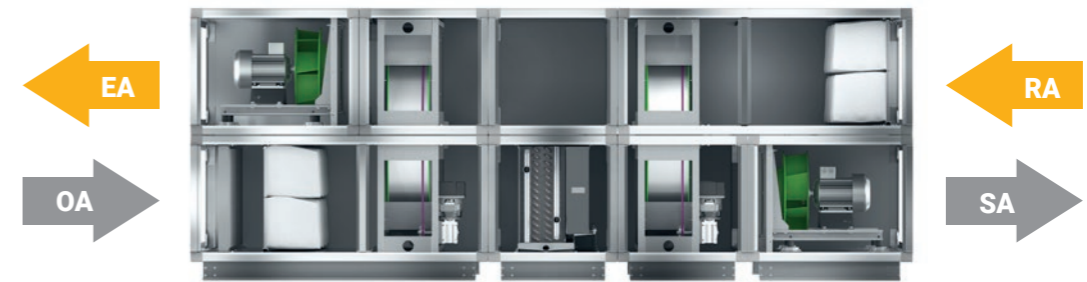

RUN-AROUND COIL

**Design and application**

- » Set of two water coils – one in supply, the other one in exhaust airstream.
- » The coil in return airstream recovers the heat (cooler) and passes it to the coil in the supply air (heater) by means of heat-transfer fluid (water-glycol mixture). In case of chill recovery, entire process is reversed.
- » System applied for supply and exhaust air handling units installed remotely to each other."

Specification

- » Indirect Energy recovery (sensible heat) at 100% supply and exhaust airstreams separation.
- » Max heat-transfer fluid operation pressure: 1,6MPa=16bar (tested 21 bar).
- » Max glycol concentration: 50%.
- » Compliance with standards: EN 308, EN 13053.
- »



WATER HEATER

**Design and application**

- » Block of copper pipes integrated with another block of aluminum fins, creating expanded heat exchange surface. Pipes are bonded to the collectors, equipped with headers (for connecting entire coil to the medium supply system).
- » Heating of the air supplied to the handled spaces.
- » Re-heating of the air as a part of air dehumidifying process.
- » The coil can be applied if heating medium is available (local boiler or district heating system).
- » Coil headers are equipped with medium damping valve and air vent.
- » Connecting the coil in parallel medium flow vs air, will result in its capacity reduction by over a dozen percent.

Specification

- » Max glycol concentration: 50%.
- » Max medium temperature: 150°C.
- » Max medium working pressure: 1,6MPa = 16bar (test: 21bar).
- » Heating capacity: parameter resulting from individual performance calculation of selected unit (CCOL).
- » Medium side pressure drop – parameter resulting from individual performance calculation of selected unit (CCOL).
- » Compliance with standards: EN 305, EN 1216, EN 13053.

ELECTRIC HEATER

**Design and application**

- » Set of resistive heating elements made of CR-Ni-Fe alloy, 6 kW/400V each.
- » Coils mounted on hot-dip galvanized steel frame.
- » Heater is equipped with power terminals and thermostat protecting against overheating.
- » In case of AHU with complete controls, heater is equipped with integrated capacity control module.
- » Heating capacity can be modified by means of smooth regulation module (HE module, set of Solid State Relays as optional parts of AHU controls) or by means of automatic engaging of next heating sections.

Specification

- » Max permissible ambient temperature around heating elements: 65°C.

WRAP-AROUND HEAT PIPES

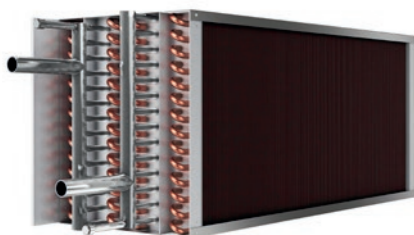
**Design and application**

- » Wrap around dehumidifier heat pipes are passive devices intended for use in air conditioning equipment to enhance dehumidification, reduce load on air conditioning equipment, and reduce or eliminate reheat.
- » The Wrap-Around Heat Pipe consists of: a pre-cool DX coil, a re-heat DX coil and heat pipes connecting the coils. The two heat pipe coils are designed to be installed around the existing cooling coil. Cooling coil can be either chilled water or DX.

Specification

- » Working medium: R134a
- » Tested for pressure: 1.3 MPa (13 Bar)
- » Fin thickness: 0,1mm
- » Row number: 1-3
- » FPI: 9-15
- » Compliance with standards: EN 305, EN 1216, EN 13053.

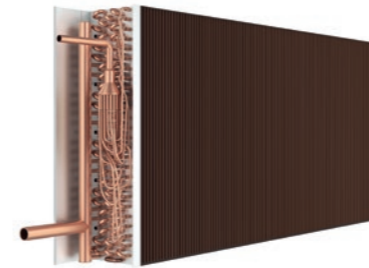

DIRECT EXPANSION COIL AS CONDENSER IN HEAT PUMP CIRCUIT

**Design and application**

- » Block of copper pipes integrated with another block of aluminum fins, creating expanded heat exchange surface. Pipes are bonded to the collectors, equipped with headers (for connecting entire coil to the cooling system circuit).
- » Heating of the air supplied to the handled spaces.
- » Re-heating of the air as a part of air dehumidifying process.

Specification

- » Max medium temperature: 60°C.
- » Max medium working pressure: 3,84MPa = 38,4bar (test: 50bar).
- » Heating capacity: parameter resulting from individual performance calculation of selected unit (CCOL).
- » Compliance with standards: EN 305, EN 1216, EN 13053.

WATER COOLER

**Design and application**

- » Block of copper pipes integrated with another block of aluminum fins, creating expanded heat exchange surface. Pipes are bonded to the collectors, equipped with headers (for connecting entire coil to the medium supply system).
- » Cooling of the air supplied to handled spaces.
- » Cooling and dehumidifying of the air as a part of air complex dehumidifying process in summer season.
- » Coil can be applied in complex air conditioning systems consisting of few or over a dozen of units supplied from common chilling source (chiller) or in case of single unit of relatively high cooling capacity.

Specification

- » Max glycol concentration: 50%.
- » Min supplying medium temperature: +2°C.
- » max medium working pressure: 1,6MPa = 16bar (test: 21bar).
- » Cooling capacity: parameter resulting from individual parameters of selected unit (CCOL).
- » Medium pressure drop / flow rate: parameter resulting from individual performance calculation of selected unit (CCOL).
- » For reversed operation mode (heating) max medium working temperature: 140°C.
- » Compliance with standards: EN 305, EN 1216, EN 13053.

DX COOLING COIL

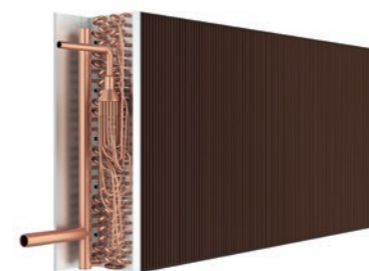
**Design and application**

- » Block of copper pipes integrated with another block of aluminum fins, creating expanded heat exchange surface. Pipes are bonded to the collectors, equipped with headers (for connecting entire coil to the cooling system circuit).
- » DX cooler is also available as heater execution (so called Condenser).
- » Cooling and dehumidifying of the air as a part of air complex dehumidifying process in summer season.
- » Coil usually applied for smaller cooling capacity systems vs water coolers or for individual air conditioning systems.

Specification

- » Min. Refrigerant evaporation temperature: +3°C.
- » Max refrigerant working pressure: 2,2MPa=22bar (test: 29 bar).
- » Cooling capacity - parameter resulting from individual performance calculation of selected unit (CCOL).
- » Compliance with standards: EN 305, EN 1216, EN 13053.



EVAPORATIVE HUMIDIFIER

**Design and application**

- » Humidifying process based on water adiabatic evaporation from the humidifier pad.
- » Humidifying pad made of CELDEK II material.
- » Humidifier housing made of stainless steel.
- » System of direct water dropping (VVS021-VVS055).
- » System of water recirculation aided by pump (VVS075-VVS650).
- » Droplet eliminator integrated with humidifier filling (VVS075-VVS650).
- » System is equipped with water drainage system preventing against high water level in the pan and floating valve controlling its refilling (VVS075-VVS 650).

Specification

- » Max air face velocity across the humidifier pad: 3,00 m/s (VS 21-VS 55); 4,00 m/s (VS 75-VS 650).
- » Water pressure range: 0,15 ÷ 0,75 MPa.
- » Requirements regarding water quality – standard tap water.

SOUND ATTENUATING SECTION

**Design and application**

- » Sound attenuator consists of noise attenuating bars installed in the AHU casing.
- » Attenuating bars of 140 mm width filled with sound-absorbing, inflammable mineral wool (density: 60 and 80 kg/m³).
- » Attenuating bar housing: frame made of hot-dip galvanized steel.
- » Bar outer surface: thin veil preventing against bar filling migration to the air.
- » Number of attenuating bars: 2÷13, depending on block size.

Specification

- » Max air face velocity: v=5m/s.
- » Working conditions: -40 ÷ +70°C.

INTERNAL LIGHT

**Design and application**

- » Energy saving lamp with securing shade.
- » Facilitation of AHU inspection actions: filter, fan and humidifier compartment.

Specification

- » Working conditions: -40 ÷ +70°C.



AIR DAMPER

**Design and application**

- » Blades made of aluminium with rubber gasket on the edges.
- » Aluminum frame.
- » Blades drive realized by means of gears made of composite material, installed on frame internal side.
- » Damper is equipped with square pivot, fitted for actuator (dampers of cross section greater than 4 m² have 2 linked pivots).

Specification

- » Air leakage at closed damper: 50 m³/h*m² - at 100 Pascals of pressure difference.
- » Working temperature range: -40 ÷ +70°C.

FLEXIBLE CONNECTION

**Design and application**

- » Flexible connection made of 1 mm thick and 30 mm wide hot-dip galvanized steel profiles and polyester fabric coated with PVC.
- » Flame resistance: UL94 - HB [ISO 1210].
- » Flexible connection resistant to UV radiation.
- » Working temperature range: -30°C do +70°C.
- » Max connection length (fully spread position): 110 mm.
- » Flexible connection installed on each AHU/Duct joint eliminates transfer of possible AHU vibrations to the ventilation ductwork.

Specification

- » Max air face velocity: 5m/s.
- » Working conditions: -40 ÷ +70°C.

AIR INTAKE AND DISCHARGE LOUVERS

**Design and application**

- » Air intake louver made of aluminum profile, blades made of ABS material.
- » Air outlet louver made of aluminum profile, blades made of ABS material.
- » Protection of air handling unit installed outdoor against meteorological conditions (precipitation, sand).

Specification

- » Max air face velocity: 5m/s.
- » Working conditions: -40 ÷ +70°C.



CONTROLS

All controls for VENTUS air handling units is available as optional equipment.

Range of controls is always fitted to configuration of the AHU selected in the CCOL4 tool. Controls is capable to regulate all user parameters: air temperature, its humidity, maximum permissible CO₂ concentration and the flow rate. Also, controls support preventive and securing functions like protection of the water heater against freezing or energy recovery system against icing, protection of motors against overloading, monitoring of air filters actual status of contamination and many other. Applied algorithms can optimize performance of all air treatment components in order to minimize consumption of all energy media supplied to the unit.

The system includes control and power supply circuit.



USER



HMI Basic

- » Engaging and disengaging the AHU, change of operational modes.
- » Change of temperature, airflow, humidity, max CO₂ level settings, etc.
- » Errors reporting.
- » Time schedule setting.



HMI Advanced

- » All users and service functions except visualization
 - AHU engaging and disengaging,
 - Change of operational modes.
- » Change of temperature, airflow, humidity, max CO₂ level settings, etc.
- » Parameters setting and reporting.
- » Errors reporting.
- » Time schedule setting.



BMS

- » User function like in HMI Advanced.
- » User's customized visualization (BMS).



Remote visualization

- » All user function like in HMI Advanced:
 - VTS visualization.
- » Clear interface of schedule programming, presenting unit's operating time individually for each day of the week.
- » Energy consumption analysing module.
- » Individual parameters monitoring of each functional block.
- » Filing of all AHU's parameters recorded in few minutes intervals.



PAREMETERS REGULATION FUNCTIONS

Regulation of temperature and humidity

- » Regulation of supply, return air temperature and humidity in handled spaces.
- » Control of water coils valves (heater, cooler) and condensing unit.
- » Control of rotary heat wheel revolutions, by-pass damper and mixing box, depending on AHU type and configuration.

Airflow rate regulation

- » Constant Air Volume (CAV) available as standard.
- » Constant static pressure maintenance in trunk duct (Variable Air Volume – VAV) available as option.
- » Setting of constant revolutions for each fan individually – VFD setting for AC motors or constant revolutions percentage in case of EC motors.

CO₂ regulation

- » By means of mixing box – for units with air recirculation.
- » By means of airflow rate change – for all types of supply and exhaust units (function can be engages together with mixing box control).

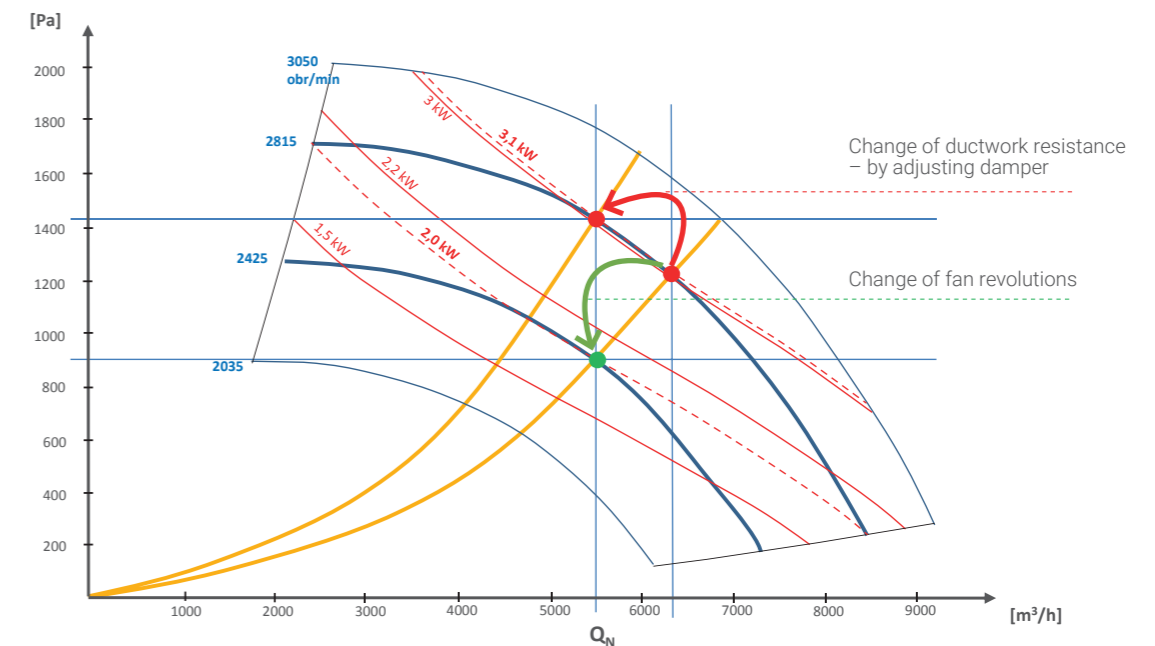

PROTECTION FUNCTIONS

- » Protection against rotary heat wheel icing, by means of wheel revolutions reduction.
- » Protection against hexagonal counterflow and cross-flow recuperator icing by means of by-pass damper opening. Functions realized as optional:
 - Optimizing of icing protection function by change of minimum return air temperature threshold downstream the energy recovery unit vs return air parameters.
 - Minimizing of recovery efficiency drop during defrosting
- » Anti-freezing protection of water heater
 - Antifreeze thermostat installed downstream the heater
 - Strap-on return water temperature sensor
- » Fans overload protection (functions realized by EC motors drives)
- » Fire alarm input – AHU immediate disengaging in case of lack of external start permission from overall fire protection system.



PREVENTIVE FUNCTIONS

- » Constant filter contamination status control:
 - Constant monitoring of filter pressure drop by means of static pressure transducers,
 - Evaluation of filter contamination status for vs actual airflow rate.
- » Fans shutting-down delay – fan's run out for systems with electric heater
- » Water heater pre-heating before fan's start up.
- » Periodical heater pump engaging in summer – to prevent against limescale accumulation
- » Opening of water heater regulation valve before engaging the fans.

TIME SCHEDULE FUNCTIONS

- » Weekly schedule operational modes programming (HMI Advanced i Basic).
- » Clear visualization of schedule settings by means of web-browser (computers and mobile devices).

POWER SUPPLY AND CONTROL CIRCUITS

- » The mains component of the controls is the control box – with microprocessor controller installed inside. The control box is usually mounted on side wall of the AHU or in units direct vicinity.
- » Control box is equipped with controller, power protection circuits, terminal block enabling connecting of all control elements.
- » Electric protection of fans, rotary heat wheel drive, control elements and heater pump are installed inside the control box.
- » Control of fan-sets (variable frequency drives in case of AC motors of specialized drives for EC ones) is realized by means of digital communication based on ModBUS protocol. Fan control elements are set with individual address enabling them to be properly identified in the control system.
- » Communication with static pressure and CO2 transducers also realized by ModBUS protocol.
- » For other control elements, digital or analogue signals are used.

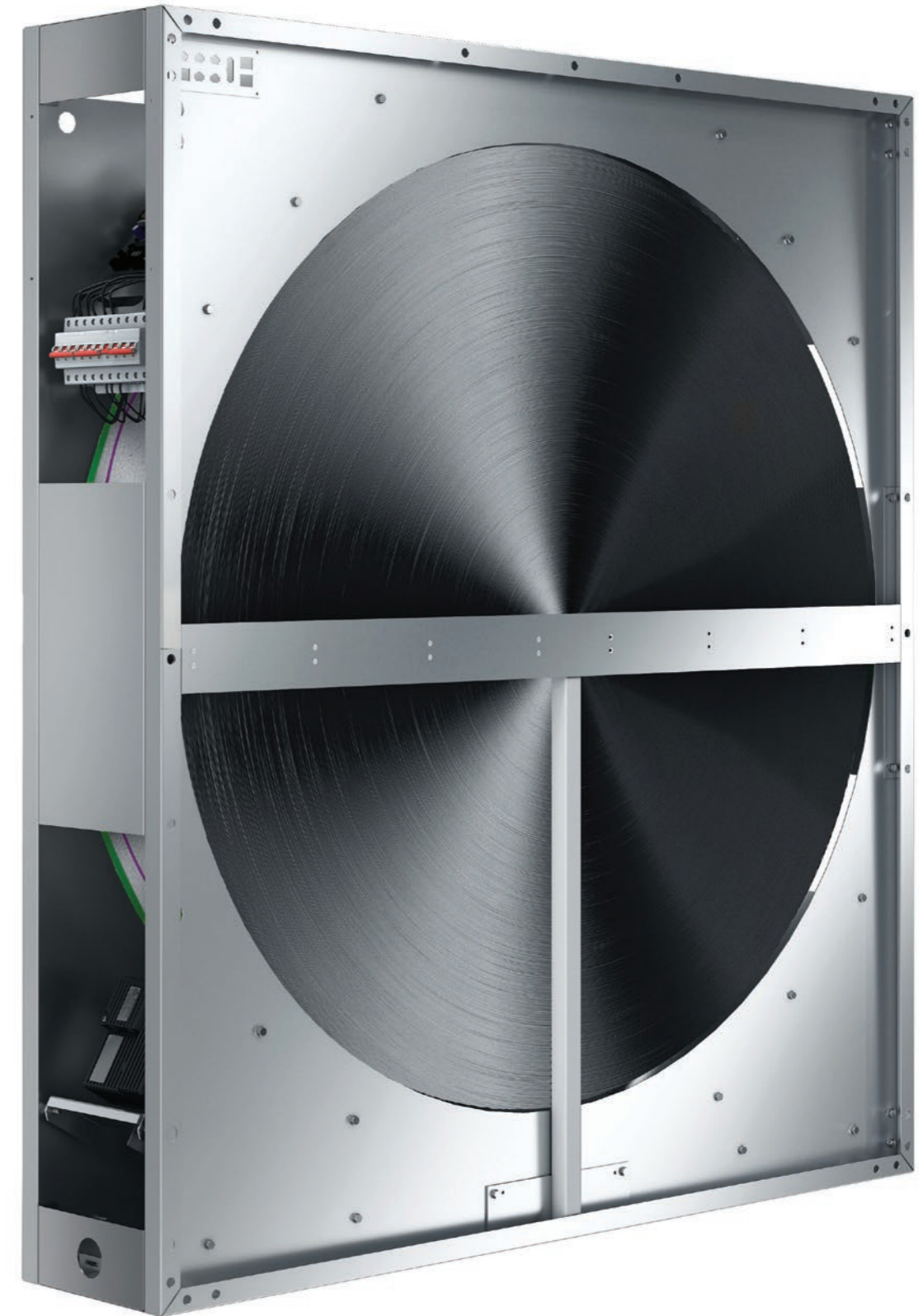

CONTROL ELEMENTS

CONTROL ELEMENTS



Functions and application

- » Regulation of supply and exhaust air temperature.
- » Protection of the energy recovery unit against freezing.
- » Outdoor air temperature measurement in order to identify need of heat/chill recovery and engagement protecting function for water heater.

Operational parameters

- » Measurement range: -50°C to +90°C.
- » Measurement accuracy: ±0,5K.
- » Sensor type: NTC 10k.
- » Air humidity range: 5 ÷ 100%.
- » Protection degree: IP67.
- » Shielded cable length: max. 100 m.

ROOM AIR TEMPERATURE SENSOR



Functions and application

- » Regulation of temperature in handled space.

Operational parameters

- » Measurement range: -20°C do +70°C.
- » Measurement accuracy: ±0,5K.
- » Sensor type: NTC 10k.
- » Air humidity range: 5 ÷ 95% no condensation.
- » Protection degree: IP20.
- » Shielded cable length: max. 100 m.

STRAP-ON MEDIUM TEMPERATURE SENSOR



Functions and application

- » Protection of water heater against freezing by means of return medium temperature monitoring.

(Function supported by controller. Sensor out of VTS offer.)

Operational parameters

- » Measurement range: -20°C do +70°C.
- » Measurement accuracy: ±0,5K.
- » Sensor type: NTC 10k.
- » Air humidity range: 5 ÷ 100%.
- » Protection degree: IP67.
- » Shielded cable length: max. 100 m.

ANTI-FREEZE THERMOSTATE



Functions and application

- » Protection of water heater against freezing by means of air off-coil temperature monitoring (recommended temperature threshold setting: +5°C).

Operational parameters

- » Measurement range: -18 ÷ +15°C.
- » Hysteresis: 1,7 ÷ 12K.
- » Nominal voltage: 30V DC or 230V AC.
- » Output signal: potential-free contact.
- » Protection degree: IP 44.

OVERHEAT PROTECTION THERMOSTATE FOR ELECTRIC HEATER



Functions and application

- » Protection of electric heater against overheating.

Operational parameters

- » Power cut-off temperature setpoint: 65°C.
- » Power re-switch on temperature setpoint : 45°C.
- » Nominal voltage: 20V DC or 230V AC.
- » Output signal: potential-free contact.

DIFFERENTIAL PRESSURE SWITCH



Functions and application

- » Monitoring of filter's contamination.
- » Control of the operation of a direct driven fan unit in case of cooperation with electric heater.

Operational parameters

- » Measurement range: 30 do 500 Pa.
- » Nominal operating voltage: 250V AC (Imax=3A).
- » Output signal: potential free contact.
- » Working temperature range: -20°C do 60°C.
- » Protection degree: IP 54.

FILTER CONTAMINATION INDICATOR



Functions and application

- » Measurement of air pressure drop on filters, activated manually (button).
- » Signal light (LED) informing about exceeding pressure drop thresholds.
- » Low battery warning light signal.

Operational parameters

- » Max. Pressure difference: 800 Pa.
- » Accuracy: 2,5% of the range.
- » Protection degree (interface side): IP 65.

DIFFERENTIAL PRESSURE TRANSDUCER

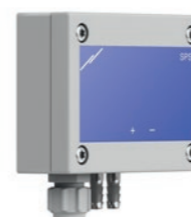

Functions and application

- » Regulation of supply and exhaust air (CAV function).
- » Regulation of static pressure in ventilation system trunk duct (VAV function).
- » Constant monitoring of filter pressure drop (control of filter contamination level).

Operational parameters

- » Measurement range: 6000 Pa.
- » Measurement accuracy: 0,25% of the range.
- » Communication: ModBus RTU.
- » Supply voltage: 21,5V to 30V DC or 21,5V do 26,5V AC.
- » Working temperature range: -20°C do 50°C.
- » Protection degree: IP 65.

AIR HUMIDITY TRANSDUCER



Functions and application

- » Regulation of supply and return air humidity in handled spaces (support for air humidifying and dehumidifying).
- » Measurement of return air humidity – automatic change of anti-freeze threshold temperature setting of cross-flow recuperator depending on return air parameters*.

* Also available as integrated with air temperature sensor

Operational parameters

- » Measurement range: 0-100%.
- » Tolerance: +/- 3%.
- » Communication: ModBus RTU.
- » Supply voltage: 24V DC.
- » Working temperature: -40°C to 80°C.
- » Protection degree: IP 65.

CO₂ TRANSDUCER



Functions and application

- » Regulation of CO₂ concentration in handled spaces (control of mixing box or airflow rate).

Operational parameters

- » Measurement range: 0 do 2000 ppm.
- » Tolerance:
 - between 400 and 1250 ppm: +/-3%,
 - between 1250 and 2000 ppm: +/-5%.
- » Communication: ModBus RTU.
- » Supply voltage: 24V DC.
- » Working temperature: 0 do 50°C.
- » Protection degree: IP 54.

ON/OFF DAMPER ACTUATOR



Functions and application

- » Airflow opening or closing in the AHU (connectors of air intake and discharge) – for units with water heater actuators with return spring are applied.

Operational parameters

- » Regulation mode: ON/OFF (two-point).
- » Angle of rotation: 90°.
- » Torque: 16 Nm (max damper cross-section: 4 m²).
- » Full open/close time: 120 s (with spring: 10 s).
- » Supply voltage: 24V AC/DC.
- » Working temperature: -20°C do 50°C.
- » Protection degree: IP 54.

SMOOTH CONTROL DAMPER ACTUATOR



Functions and application

- » Smooth regulation of return and fresh air mixing (recirculation) – for units with water heater actuators with return spring are applied.
- » Protection of cross-plate or hexagonal recuperator against frosting – smooth regulation of bypass damper opening.

Operational parameters

- » Regulation mode: 0 do 100% (smooth).
- » Control signal: 0-10V.
- » Angle de rotation: 90°.
- » Torque: 16 Nm (max damper cross-section: 4 m²).
- » Full open/close time: 90s (with spring: 10 s).
- » Supply voltage: 24V AC/DC.
- » Working temperature: -20°C do 50°C.
- » Protection degree: IP 54.

THREE-WAY VALVE FOR WATER HEATER OR COOLER



Functions and application

- » Smooth regulation of water heater or cooler capacity.

Operational parameters

- » Regulation mode: 0 do 100% (smooth).
- » Control signal: 0-10V.
- » Full open/close time: 90 s.
- » Valve supply voltage: 24V AC/DC.
- » Working temperature: +5°C do 50°C.
- » Medium temperature range: -10°C do 120°C.
- » Max glycol concentration: 50%.
- » Protection degree: IP 54.

ELECTRIC HEATER CONTROL MODULE – MHE TYPE



Functions and application

- » Power supply, protection and smooth regulation of electric (heating) capacity of multi-stage electric heaters by means of PWM (Pulse Width Modulation).

Operational parameters

- » Regulation mode: 0 to 100% (smooth).
- » Nominal voltage: 3*400V/50Hz.
- » Control circuits supply voltage: 24V AC.
- » Binary input signal: 3 x 24V DC.
- » Binary output signal 6 x 24V DC.
- » PWM 1 x 24V DC.
- » Working temperature: 0°C do 50°C.

VARIABLE FREQUENCY DRIVE



Functions and application

- » Smooth regulation of fan-set capacity.
- » "Soft-start" of the fan without mechanical and electric shock.
- » Motor protection against overloading and stucking.

Operational parameters

- » Frequency regulation range: 10 ÷ 100 Hz.
- » Communication: ModBus RTU RS485.
- » Supply voltage:
 - single-phase 200 ÷ 240V AC,
 - three-phase 380 ÷ 480V AC.
- » Working temperature: 0°C to 40°C.
- » Protection degree: IP 20.



HMI BASIC USER INTERFACE



Functions and application

- » Maintenance of Air handling unit – temperatures setting and reading, change of operating modes, independent time schedule management, alarm codes displaying.
- » Configuration of controller's universal inputs and outputs.

Operational parameters

- » Power supply directly from the controller.
- » Communication with controller – RS485 serial port.
- » Max length of communication cable: max. 500 m.
- » Working temperature: -20°C to 60°C.
- » Humidity: <85% (no condensation).
- » Protection degree: IP 31.

HMI ADVANCED USER INTERFACE



Functions and application

- » Maintenance of Air handling Unit – parameters setting and reading (temperature, airflow, CO₂, humidity etc), change of operational modes.
- » Weekly schedule programming.
- » Service maintenance – configuration of all advanced AHU operating parameters, configuration controllers universal inputs and outputs.
- » Remote configuring of variable frequency drives.
- » AHU alarms and errors monitoring (full text description) and cancelling.

Operational parameters

- » Power supply directly from the controller
- » Communication with controller – RS485 serial port
- » Max length of communication cable: max. 1200 m,
- » Working temperature: -20°C to 60°C.
- » Humidity: <85% (no condensation).
- » Protection degree: IP 31.

SUPPLY AND CONTROL BOX



Functions and application

- » Control of all components and processes of Air Handling Unit, especially realization of regulation (temperature, airflow, CO₂, humidity) and protection functions (anti-freezing of energy recovery heat exchanger or water heater, fan-sets overloading etc).
- » Alarms handling, self-diagnostics.
- » Filling of all operating parameters history.
- » Communication with user interfaces (HMI).

Operational parameters

- » Supply voltage: 3x400 VAC or 1x230 V AC.
- » Supply frequency: 50 Hz, +/- 1 Hz.
- » Control circuits supply voltage: 24 V AC.
- » Water heater pump supply voltage: 230 V AC (max.10A).
- » Communication with internal controls circuits, VFD's or EC motors controller: ModBus RTU.
- » ModBus communication: TCP/IP.
- » Working temperature: 0 to 50°C.
- » Humidity: <85% (no condensation).
- » Protection degree: IP 54.





04

Units
- VENTUS S-type



VENTUS

S-TYPE

TECHNICAL SPECIFICATIONS

CASING

- 50 mm "Sandwich" double skin panels made of rigid polyurethane foam
- Inspection panels mounted on AHU side
- High anticorrosive protection:
 - Galvanized zinc (Zn) coating: 180g/m²
 - External protection coating material thickness: polyester / 25µm
- Inspection panels on both sides

AIR FILTERS

- Pleated filtration fabric shielded by steel net, installed in 50 mm thick frame
- Filtration fabric made of polyester fibres
- Working max parameters: max temperature (+70)°C, max. RH100%
- ISO Coarse 75% (ISO 16890) - G4 (EN779)

COOLING COIL

- Hydronic coils - 4, 6 rows available
- DX - 6 rows, 2 sections available
- Max operating pressure - 1,6 MPa
- Testing pressure - 2,1 MPa
- Drain tray: stainless steel, water outlet 1"

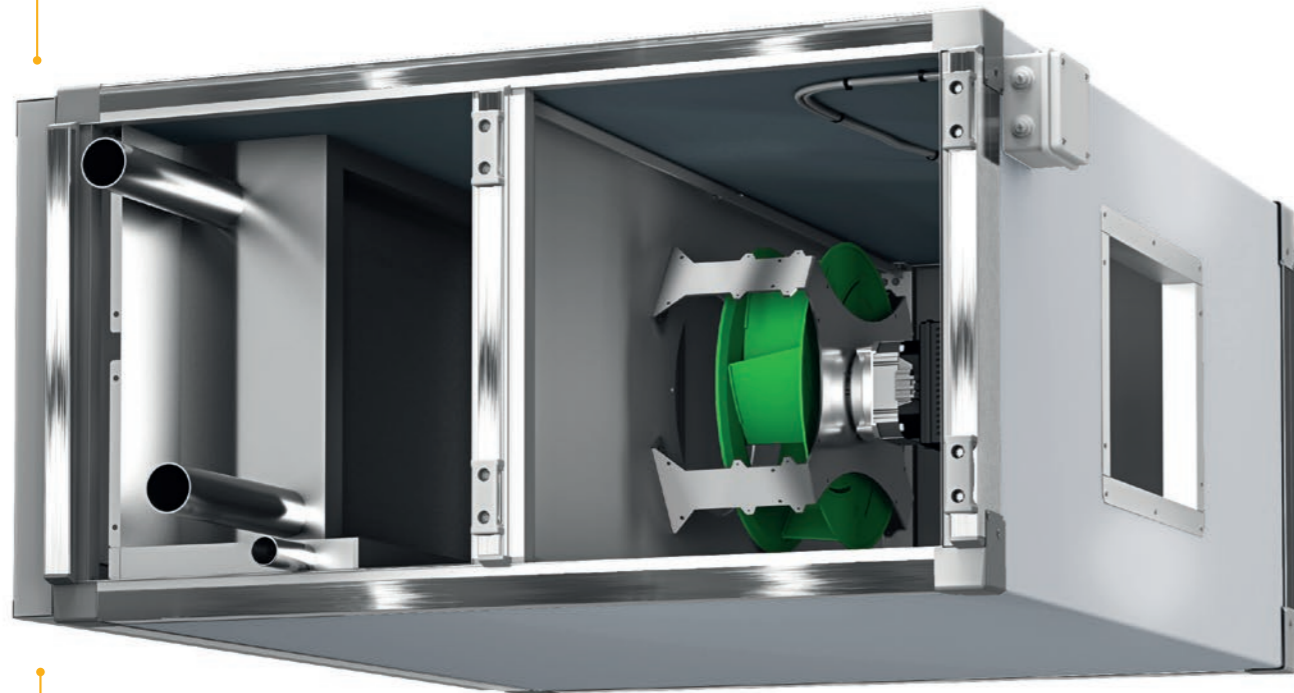

DIRECT DRIVE PLUG FAN SET > BLOWER

- Single inlet, radial, backward curved, free running fan
- Direct drive – fan impeller installed directly on motor shaft
- Fan section consisting of single or twin fans
- Smooth regulation

DIRECT DRIVE PLUG FAN SET > AC MOTORS

- Fan and motor mounted on common housing, separated from AHU casing by set of rubber vibration absorbing mounts
- Motors of TEFS (Totally Enclosed, Fan-Cooled)
- Variable Frequency Drive (VFD) – standard part of the fan-set
- Available Energy classes: IE2
- Junction box on casing

DIRECT DRIVE PLUG FAN SET > EC MOTORS

- Set of fan and motor mounted on common rail, fixed to the AHU fan diaphragm.
- EC motors are Permanent Magnet motor, characterised by much higher efficiency vs traditional inductive AC motors.
- Required regulation with 0-10V regulator or ModBus signal
- Junction box on casing

UNIT CASING:

Monocoque technology - a self supporting shell structure used in Formula 1 car and aviation. This is exactly how we design our products, therefore our units feature low weight and optimal height, are easy for transportation and further installation. Moreover double skin "sandwich" panels with 50 mm rigid polyurethane foam ensure best thermal insulation.

- » Thermal conductivity: PPU $\lambda = 0,022 \text{ W/mK}$
- » PPU density: $\rho = 42 \text{ kg/m}^3$
- » Casing heat transfer coefficient: $K = 0.6 \text{ W/m}^2\text{K}$
- » Casing mechanical strength:
 - +2500 Pa ÷ 2500 Pa < 2 mm
- » Casing tightness:
 - 400 Pa - 0.05 l/sm²
 - +700 Pa - 0.13 l/sm³
- » Anticorrosive protection:
 - Galvanized zinc (Zn) coating: 180g/m²
- » External protection coating material thickness: polyester 25µm
- » Inspection panels mounted on AHU side.

NO THERMAL BRIDGES

Our Monocoque casing is a framework free construction. This eliminates the problem of water condensation on the external AHU side - and therefore - no more of harmful water dripping from the ceiling.

DRAIN TRAY

They are fabricated from heavy stainless steel and are to prevent condensation.

COOLING COILS

Fabricated from copper tubes mechanically bonded with aluminum fins and are leak tested at 305 psig pressure.

Hydronic

- » Copper pipe: dimensions: ½"
- » Fin Type: corrugated fin
- » Row: 4 or 6 rows
- » Max operating pressure: 1,6 MPa
- » Testing pressure: 2,1 MPa
- » Equipped with air discharge valve and water outlet valve

> DX

- » Copper pipe: dimensions: ½"
- » Fin Type: corrugated fin
- » Row: 6 rows, 2 - sections
- » Max operating pressure: 1,6 MPa
- » Testing pressure: 2,1 MPa

DIRECT DRIVE PLUG FAN SET

Blower

- » Single inlet, radial, backward curved, free running fan.
- » Impeller made of SAN (styrene/ acrylonitrile) construction material with 20% glass fiber.
- » Direct drive – fan impeller installed directly on motor shaft.
- » Fan section consisting of single or twin fans .

AC Motors

- » Fan and motor mounted on common housing, separated from AHU casing by set of rubber vibration absorbing mounts.
- » Motors of TEFS (Totally Enclosed, Fan-Cooled).
- » Motors fitted for IEC standard.
- » Variable Frequency Drive (VFD) – standard part of the fan-set.
- » Available Energy classes: IE2
- » Available voltage: 1x230V/50Hz, 3x380V/50Hz, 3x400V/50Hz, 3x400V/60Hz.
- » Number of poles: 2.
- » Motor winding insulation class: F (fitted for VFD operations).
- » Bearings lifetime: L10= 20000h / L50 = 100000h.
- » Protection degree: IP55.
- » Working conditions: 60°C.

EC Motors

- » Set of fan and motor mounted on common rail, fixed to the AHU fan diaphragm.
- » EC motors are Permanent Magnet motor, characterised by much higher efficiency vs traditional inductive AC motors.
- » EC motors (Electronically Commutated) – where mechanical commutator switching the windings has been replaced with electronic one.
- » Change of revolutions is done by means of changing the frequency rate of windings switching (rate or magnetic field rotating).
- » Highly inductive permanent magnets have applied in EC motors used by VTS, which enabled to achieve high torque at relatively small dimensions.
- » Rated voltage: EC motors of nominal capacity equal or less 0,75kW - 1x230V AC.
- » Motor winding insulation class: F.
- » Protection degree: IP54. » Maximum working ambient temperature: 55°C.
- » Lifespan: - 70 000 hours at load not exceeding 70% of nominal capacity at ambient temperature not exceeding 35°C, - 30 000 hours at 100% capacity load at ambient temperature not exceeding 55°C.

AIR FILTERS

- » All Units are provided with air filters.
- » Pleated filtration fabric shielded by steel net, installed in 50 mm thick frame.
- » Filtration fabric made of polyester fibres.
- » Working max parameters: max. temperature (+70)°C, max RH100%.
- » ISO Coarse 75% (ISO 16890) - G4 (EN779).

TYPICAL APPLICATION



residential buildings



industrial buildings



small businesses



sports facilities



retail and warehouses



garages and workshops

ELECTRICAL WIRING DIAGRAMS

3 phase with VFD

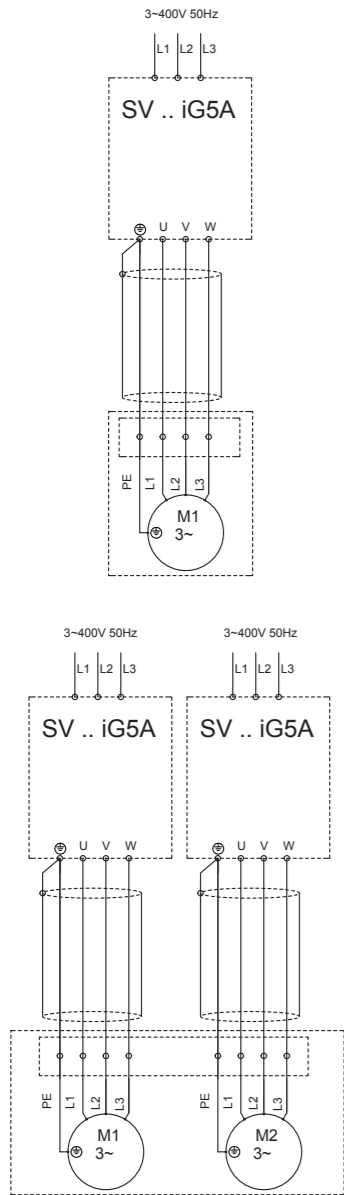

1 phase - 1 EC MOTOR

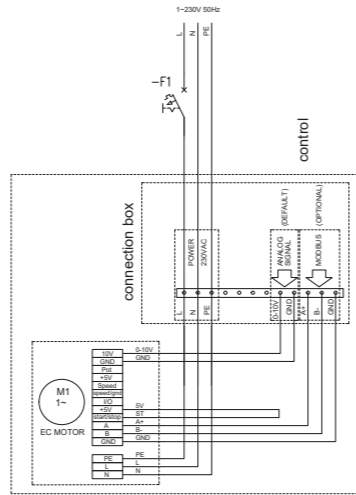

1 phase - 2 EC MOTOR

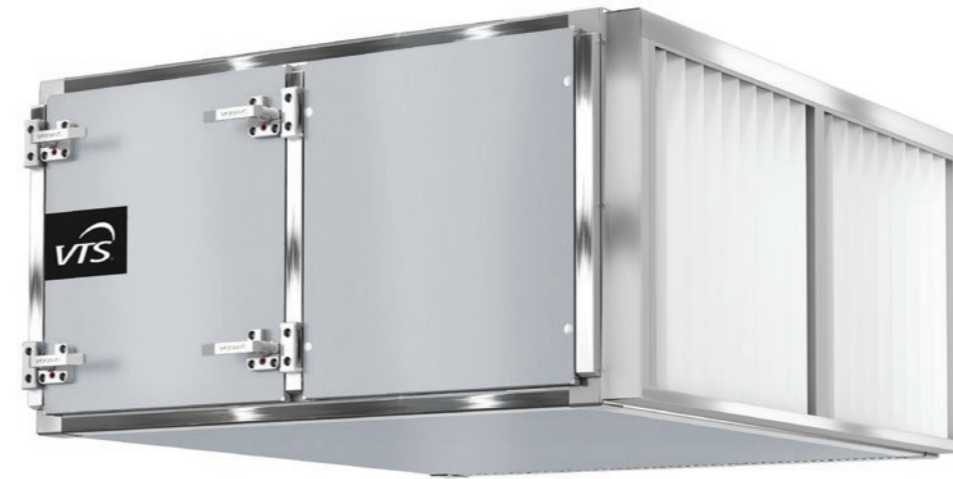
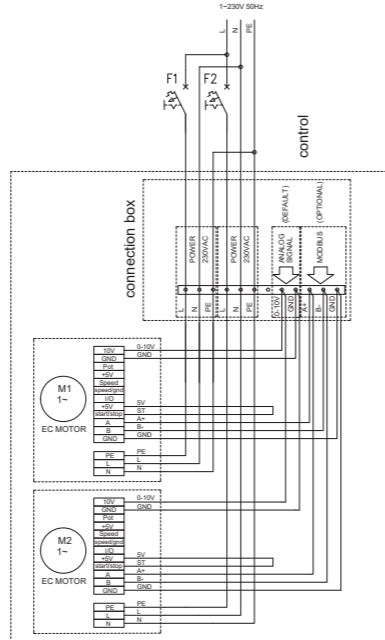

100%
units
factory tested

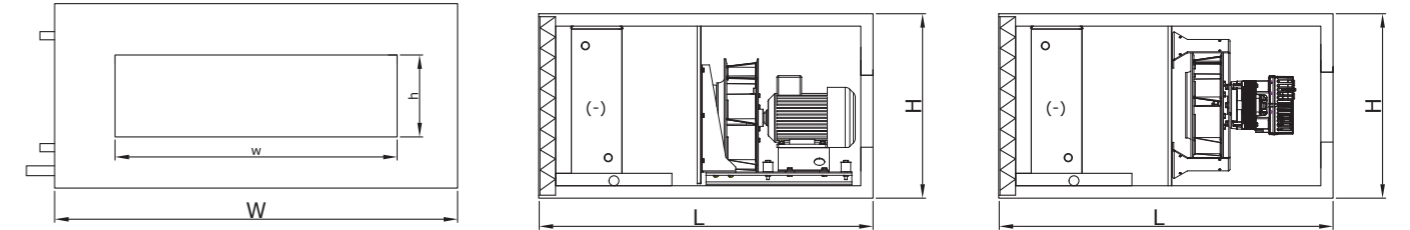

Unit size	Fan set with AC Motor									
	Model	Rated Output	Poles	Efficiency Class	Protection Grade	Rated Current at				
						415V/3ph/50Hz	230V/1ph/50Hz	380V/3ph/50Hz	400V/3ph/50Hz	400V/3ph/60Hz
SVS-35	VS 315	1,5	2	IE2	IP55 / F	3,1	5,54	3,36	3,1	3,19
SVS-50	VS 355	1,5	2	IE2	IP55 / F	3,1	5,54	3,36	3,1	3,19
SVS-70	VS 315 x 2	1,5 x 2	2	IE2	IP55 / F	6,2	11,08	6,72	6,2	6,38
SVS-85	VS 400 x 2	1,5 x 2	2	IE2	IP55 / F	6,2	11,08	6,72	6,2	6,38
SVS-100	VS 400 x 2	1,5 x 2	2	IE2	IP55 / F	6,2	11,08	6,72	6,2	6,38

Unit size	Fan set with EC Motor			
	Model	Rated Output	Protection Grade	Rated Current at 230V/1ph/50Hz
SVS-35	VS 315	0,75	IP54 / F	3,7
SVS-50	VS 315	0,75	IP54 / F	3,7
SVS-70	VS 315 x 2	0,75 x 2	IP54 / F	7,2
SVS-85	VS 315 x 2	0,75 x 2	IP54 / F	7,2
SVS-100	VS 315 x 2	0,75 x 2	IP54 / F	7,2

Unit size	Dimensions			Duct Connection	FAN	Motor	Weight *
	H	W	L				
	[mm]			h x w	Model	Rated Output	[kg]
SVS-35	550	1171	1068	210 x 700	VS 315	1,5	162
SVS-50	615	1325	1068	310x550	VS 355	1,5	220
SVS-70	550	2025	1068	310x1200	VS 315 x 2	1,5 x 2	266
SVS-85	675	2025	1068	410x1400	VS 400 x 2	1,5 x 2	249
SVS-100	675	2225	1068	410x1400	VS 400 x 2	1,5 x 2	322

Unit size	Min Air Flow		Max Air Flow		Air Flow					
	CMH	CFM	CMH	CFM	CFM					
					0	1000	2000	3000	4000	5000
SVS-35	1500	883	3500	2060	[Bar chart showing air flow range from ~1000 to ~2000 CFM]					
SVS-50	2100	1236	4500	2660	[Bar chart showing air flow range from ~1500 to ~2500 CFM]					
SVS-70	3000	1766	7000	4120	[Bar chart showing air flow range from ~2000 to ~3500 CFM]					
SVS-85	3400	2001	8500	5003	[Bar chart showing air flow range from ~2500 to ~4000 CFM]					
SVS-100	4200	2472	9500	5621	[Bar chart showing air flow range from ~3000 to ~4500 CFM]					

Unit size	Coil Volume			Coil Connections			
	WCL4R	WCL6R	DX6R	WCL4R, WCL6R		DX6R	
	[Liters]			φD _{in}	φD _{out}	φD _{in}	φD _{out}
SVS-35	6,33	9,5	9,5	DN32	DN32	2x5/8"	2xØ28
SVS-50	8,24	12,36	12,36	DN50	DN50	2xØ22	2xØ35
SVS-70	12,08	18,13	18,13	DN50	DN50	2xØ22	2xØ35
SVS-85	15,44	23,16	23,16	DN50	DN50	2xØ22	2xØ35
SVS-100	17,23	25,84	25,84	DN50	DN50	2xØ22	2xØ42

* Weight present for units with integrated 6 rows water coil and fan section with AC motor

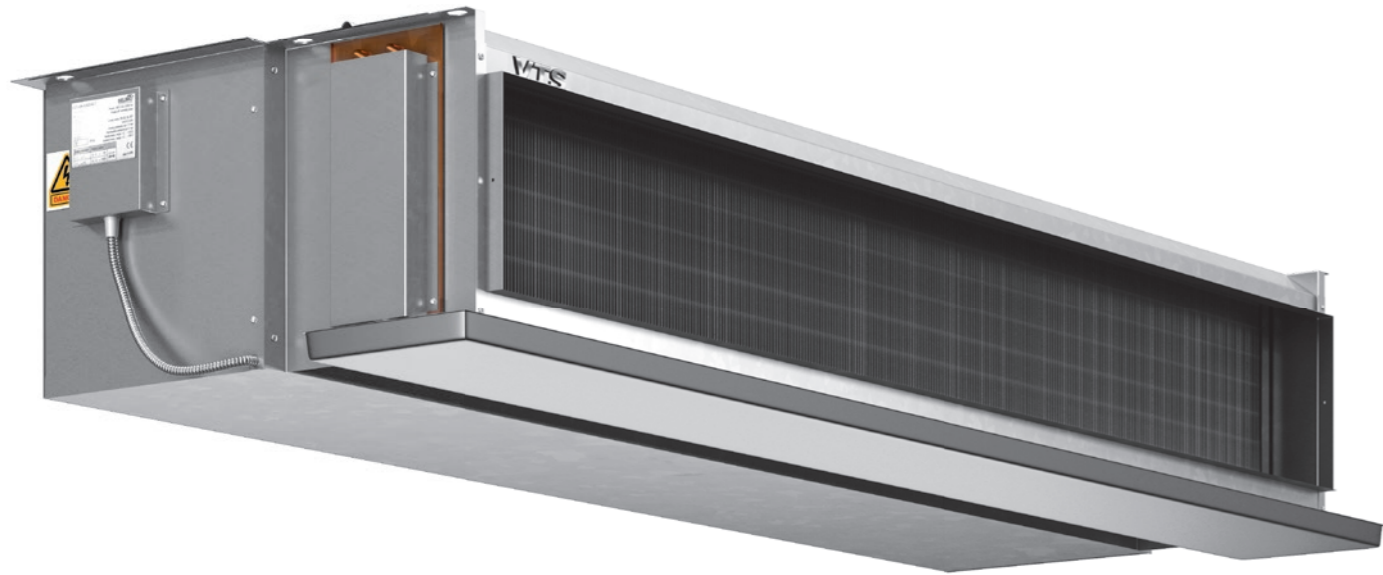

05

Fan Coil Unit



Technical Specifications

CASING

- Top cover material:
- Galvanized steel
 - Thickness: 0.8 mm

- Base material:
- Galvanized steel
 - Thickness: 0.8 mm

- Side panel material:
- Galvanized steel
 - Thickness: 0.8 mm

- Back cover:
- Galvanized steel
 - Thickness: 0.8 mm

- Top cover for plenum:
- Galvanized steel
 - Thickness: 0.8 mm

- Side panel for plenum:
- Galvanized steel
 - Thickness: 0.8 mm

- Plenum box insulation:
- 6 mm closed cell foam

COOLING COIL

- Copper pipe:
- Dimensions: 3/8" (9.52 mm)

- Fin:
- Thickness: 0.105 mm
 - Fin pitch: 10 FPI
 - Louvered type Al-fin

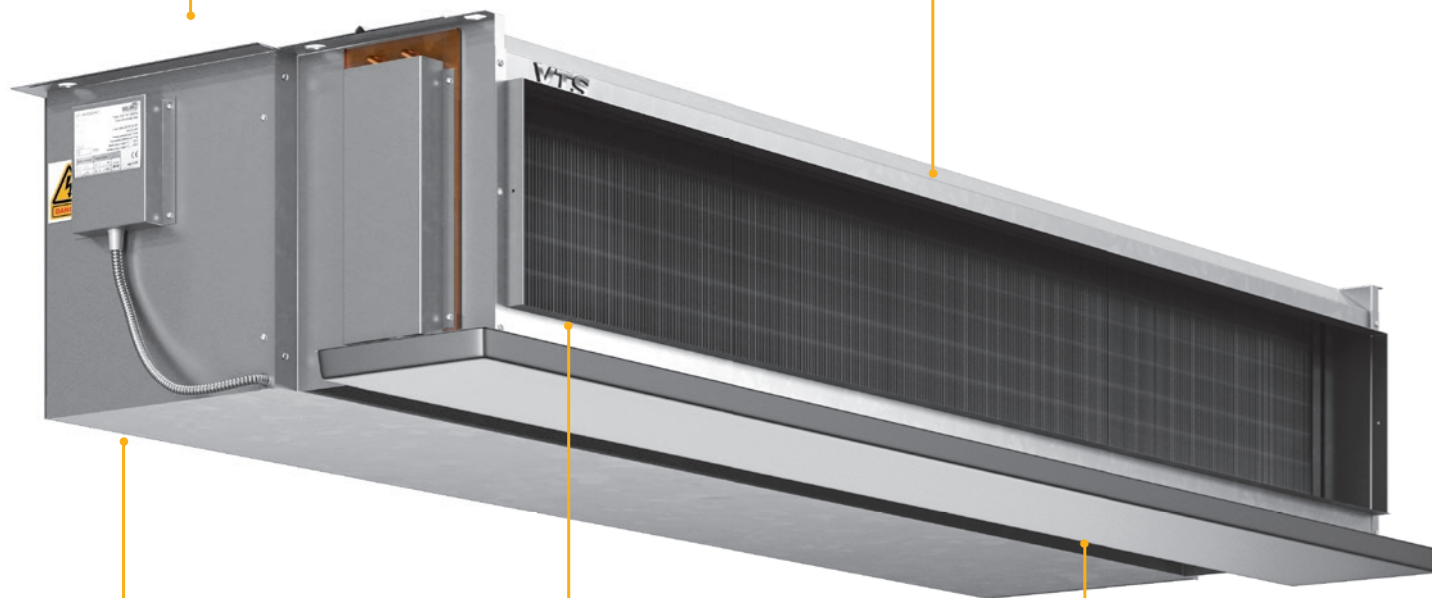

BLOWER:

- Blower material:
- Type: DIDW Forward Curved Centrifugal Fan
 - Material: Galvanized steel

- Motor:
- Type: Single phase capacitor type
 - Insulation: B
 - Protection grade: IP20

FILTER:

- Filter frame: Aluminum alloy
- Material: Double layer aluminum
- Thickness: 25 mm
- EU-2 filter grade as per EN779

DRAIN TRAY:

- Material: galvanised steel
- Thickness: 0.8 mm
- Insulation material: PE, 3 mm
- Water outlet: 3/4"
- Powder coated to RAL 9002



Typical applications:



Offices



Hotels



Hospitals



Malls

Technical Specifications

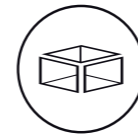

Unit Casing:

Galvanized steel casing of minimum 0.8 mm thickness. Casing is internally lined with 6mm closed cell elastomeric foam insulation.



Drain Tray:

They are fabricated from heavy gauge galvanized steel and are insulated to prevent condensation. Powder coated on both sides to RAL 9002.



Cooling Coils:

Fabricated from copper tubes mechanically bonded with aluminum fins and are leak tested at 350 Psig nitrogen pressure.

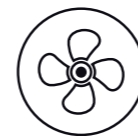

Blower:

Fans are forward curved centrifugal type of double inlet, statically and dynamically balanced to ensure quiet operation.

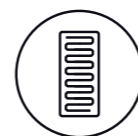

Air Filters:

All Units are provided with 25 mm Aluminum Mesh filter as a standard option. Filters accessible from rear end of the unit and is easily removable by pulling out from unit frame.



Fan Motors:

Motors are single phase, 3 speed, 220-240V/1 Phase/50 Hz with internal thermal protection. EC motors available as an option.



Options:

Double skin fan coil units with casing made of 0.8mm galvanized steel sheet and 10mm close cell insulation. Decorative fan coil units, suitable for wall or ceiling mounting.



06

WING air curtain



WING C

MAX. AIR RANGE:
4 m

EXHAUST FLOW RATE:
1950-4600 m³/h



STREAM RANGE

Vertical air stream range
(maximum installation height)

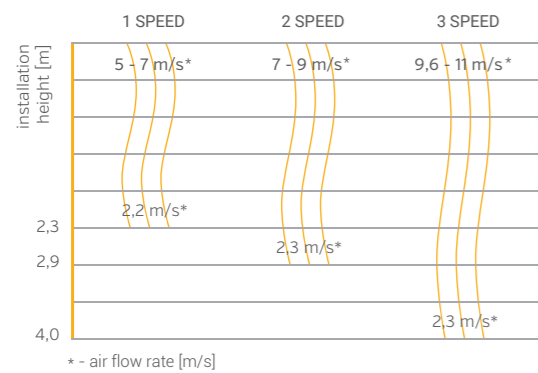

Horizontal air stream range
(for vertical installation)

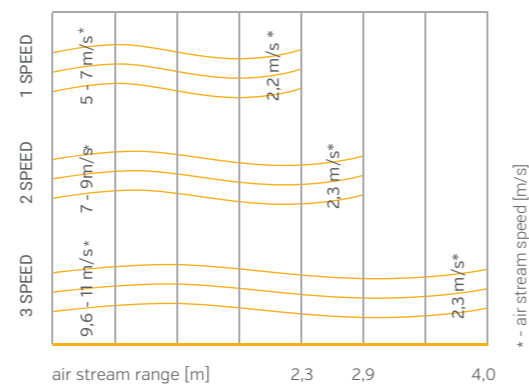

INSTALLATION

Dedicated brackets and fixing points enable immediate installation of the curtain.

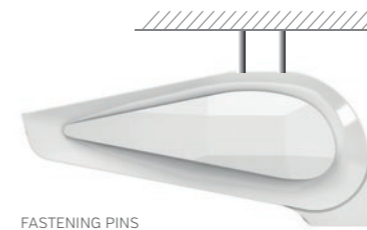
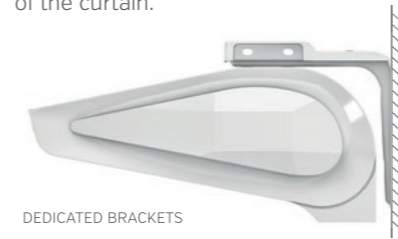

The maximum mounting height is 4m.
The minimum distance between the air outlet of the curtain and the ceiling is only 30 cm.

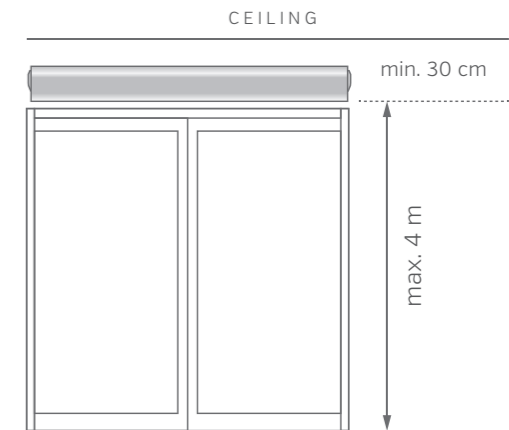

HORIZONTAL INSTALLATION

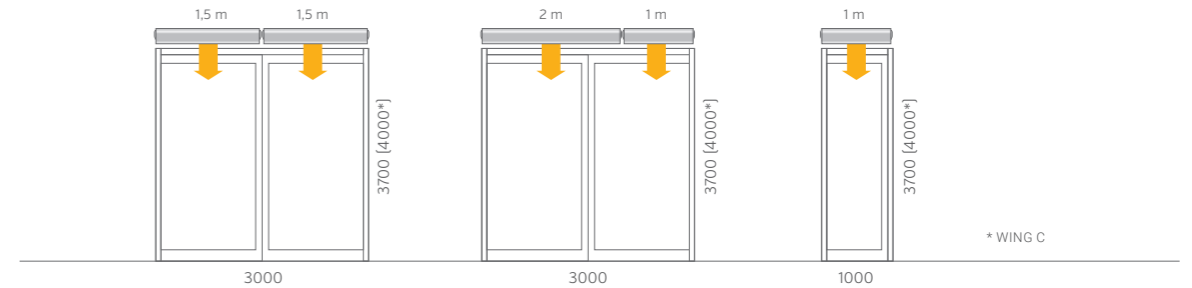

VERTICAL INSTALLATION

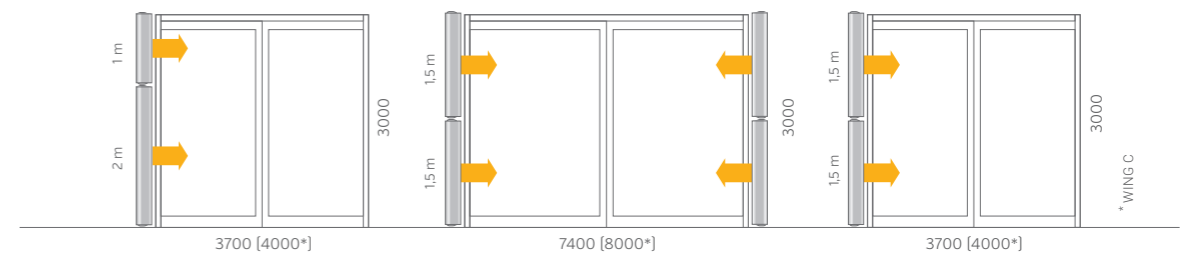

CONTROL

HMI WING EC controller		Wall controller WING/VOLCANO		Potentiometer EC (0-10 V)		Door sensor (reed switch)*	
VTS product number	1-4-2801-0155	VTS product number	1-4-0101-0438	VTS product number	1-4-0101-0453	VTS product number	1-4-0101-0454
Motor support	EC	Motor support	AC	Power supply voltage	V/ph/Hz ~230/1/50	Contact configuration	NO
Power supply voltage	V/ph/Hz ~230/1/50	Power supply voltage	V/ph/Hz ~230/1/50	Permissible load	A 0,02 A for 0-10V	Switching current	500 mA
Permissible load	A 1A for 230VAC, 0,02A for 0-10V	Permissible load	A 6(3)	Work mode	- Manual	Switching voltage	max 200 V
Setting range	°C 5...40	Settings range	°C 10...30	Protection rating	IP 30	Connection	screw
Protection rating	IP 20	Protection rating	IP 30				

* cooperation with controller WING EC

ALL EC AIR CURTAINS ARE CHARACTERIZED BY EASE AND SIMPLICITY OF CONNECTION

ELECTRICITY SAVINGS

Modern design of the EC motor and fan saves energy compared to old generation solutions.

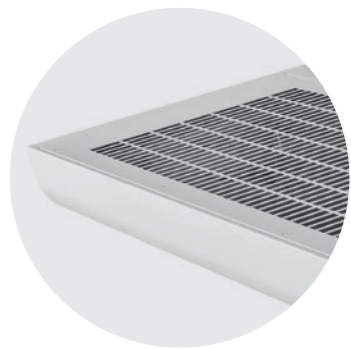

SIMPLE CLEANING

Thanks to the optimized construction of the covers, cleaning the curtain is comfortable and does not require the disassembly of any part, always ensuring hygienic operation.



GALVANIZED STEEL CASING

Double coating (galvanization + powder paint) provides long-term protection against corrosion and consistent aesthetic qualities. Casing colour RAL 9016.



SMART DOOR PROTECTION

Air curtain with advanced WING EC CONTROLER may perform according to the door opening sensor. Smart Door protection gives you not only permanent temperature comfort but also secure inside environment from dust, pollution, insects and unpleasant scents.

TECHNICAL PARAMETERS

Parameters	Unit	AMBIENT CURTAIN					
		WING C100		WING C150		WING C200	
		AC	EC	AC	EC	AC	EC
VTS item No.		1-4-2801-0256	1-4-2801-0265	1-4-2801-0257	1-4-2801-0266	1-4-2801-0258	1-4-2801-0267
maximum door width (1 device)	m	1		1,5		2	
maximum door height (vertical stream range)*	m	4					
maximum exhaust flow rate	m³/h	1950		3200		4600	
supply voltage	V/ph/Hz	~230/1/50					
motor power	kW	0,235	0,2	0,375	0,3	0,58	0,45
rated current	A	1,2	1,1	1,7	1,3	2,6	1,9
weight	kg	17,9	15,3	23,8	20,4	29,3	25,1
protection rating	IP	20					
max. velocity*	m/s	11					
casing colour	RAL	RAL 9016, outlet grid: RAL 9022					

WING C100, C150, C200 [AMBIENT CURTAIN]

Fan speed	WING C100			WING C150			WING C200		
	I	II	III	I	II	III	I	II	III
Qp [m³/h]	1050	1500	1950	1500	2250	3200	2340	3400	4600
db (A) **	53	59	62	54	62	63	57	61	63

* air stream range depends on curtain operation speed
 ** measurement conditions: semi-open space, horizontal installation on the wall, measurement performed 5m away from the device

WING KEY REALISATIONS

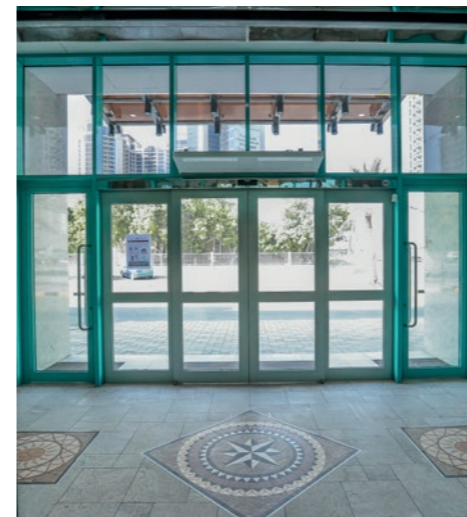

> Al Murad Mall



> The Andaz Capital Gate Hotel Abu Dhabi by Hyatt



> DEWA (Dubai Electricity & Water Authority) Office Building, Al Ruwaihah, Dubai



PSYCHROMETRIC CHART

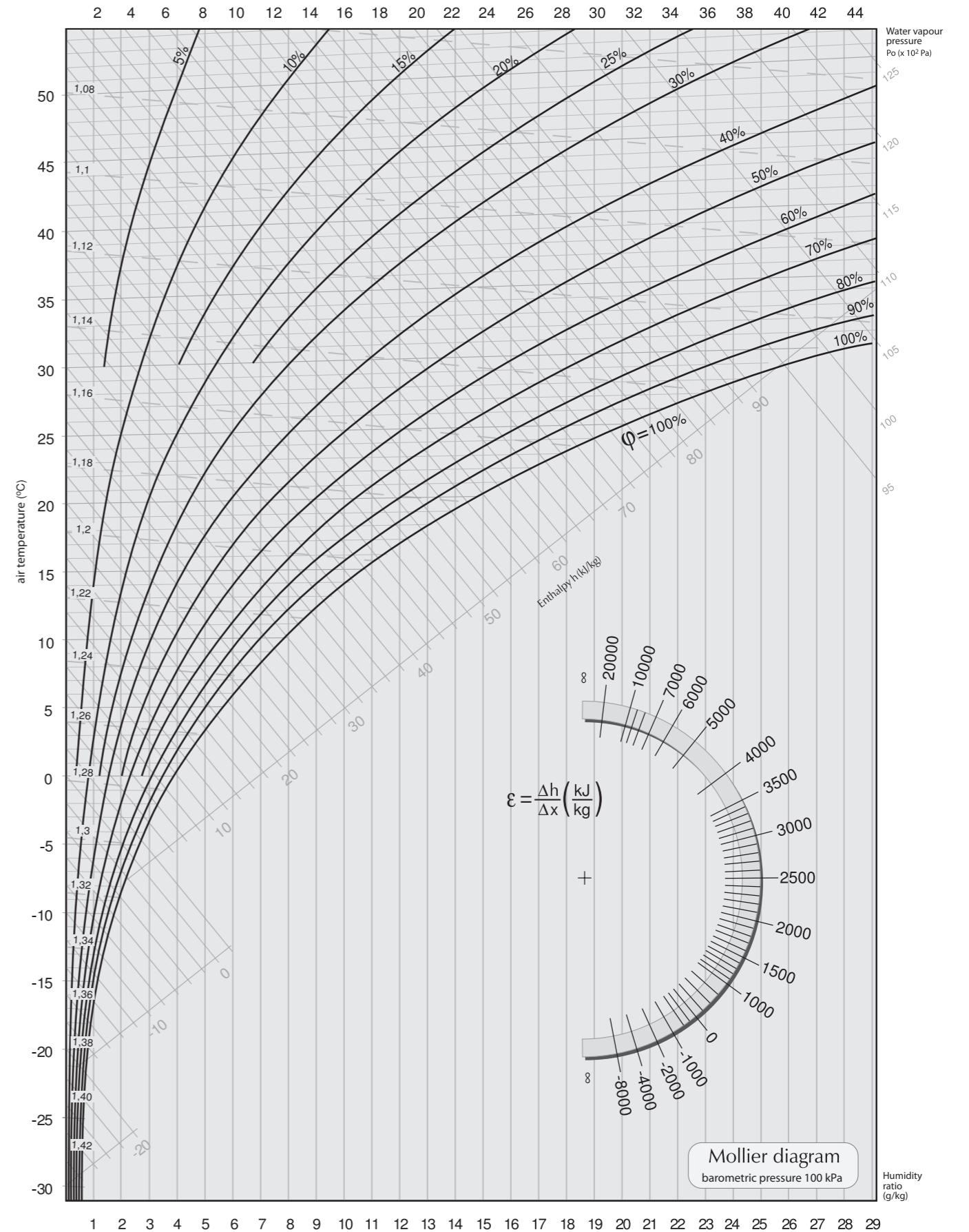



VTS Sp. z o.o.

Olivia Tower
Al. Grunwaldzka 472 A
80-309 Gdańsk, Poland
T: +48 (58) 628 13 54
F: +48 (58) 628 13 22
vtsgroup@vtsgroup.com

VTS Clima Gulf FZCO.

P.O.BOX #18061,
Plot No. S20126
Jebel Ali Freezone, Dubai - U.A.E
tel: +971 (4) 881 1945
fax: +971 (4) 889 4998
e-mail: dubai@vtsgroup.com

VTS Clima LLC - Abu Dhabi Branch

P.O.Box # 36060
1st Floor Al Hamed Building
Muroor Road, Abu Dhabi-U.A.E
Tel. + 971 (02) 6276101
Fax + 971 (02) 6276121
e-mail: abudhabi@vtsgroup.com

Due to continuous improvement of the products, VTS reserves right to implement modifications.
Some of technical data and descriptions may vary from the actual products specification.
Before placing the order, please, confirm all technical specification with VTS sales representative.